

# CODE OF PRACTICE FOR NOISE MANAGEMENT OF ON-FARM PROCESSING OF MACADAMIA NUTS

*"A GOOD NEIGHBOUR POLICY"*

**DRAFT ONLY**

Sponsored by  
Lismore City Council  
Australian Macadamia Society Limited  
NSW Department of State & Regional Development  
PlanningNSW/Living Centres

February 2003

Prepared by  
Australian Strategic Planning Pty Limited  
Level 12, 189 Kent Street, SYDNEY NSW 2000  
Phone: 02 9241 1989. Fax: 02 9241 3189  
e-mail: [email@austraplan.com.au](mailto:email@austraplan.com.au) website: [www.austraplan.com.au](http://www.austraplan.com.au)

## Foreword

The macadamia nut industry makes a substantial contribution to the economy of the Northern Rivers Region of NSW and to Australia generally. However, past land use decisions have seen the emergence of conflicts with potential noisy on-farm nut processing and orchard spraying taking place in close proximity to rural residential neighbours.

Mindful of the industry's importance, Lismore City Council (the body responsible for locally administering the noise guidelines of the NSW Environment Protection Authority's Industrial Noise Policy and the Protection of the Environment Operations [POEO] Act) is keen to identify and implement lasting outcomes which promote sustainable industry practices. In administering these guidelines and controls, Council is required to take the position of a 'reasonable person' to balance the expectations of all parties.

The approach considered to best achieve a sustainable outcome is the development of a Code of Practice containing methods of meeting noise emission standards for stationary or fixed macadamia nut processing equipment, supported by and endorsed by stakeholders in the macadamia nut industry and residents. The Code does not cover mobile machinery as the noise produced is transitional.

This is a voluntary Code of Practice which is supported by the Australian Macadamia Society Limited, Lismore City Council, Department of State and Regional Development and PlanningNSW/Living Centres.

The Code has been prepared by Australian Strategic Planning Pty Ltd in association with Sloane Cook & King Pty Ltd. The consultants who have been involved in its preparation are Richard Dougan, Team Leader and Regulatory Adviser; Brian Watson, Agricultural Economist; Ken Scannell, Noise and Sound Services Expert; and Graham Meineke, Planning Adviser.

The macadamia industry and the Lismore City Council are to be commended for their pro-active approach to resolving what could be major problems between rural residents and farmers/growers in the near term.

## Table of Contents

	<u>page</u>
FOREWORD .....	I
CODE OF PRACTICE FOR NOISE MANAGEMENT OF ON-FARM PROCESSING OF MACADAMIA NUTS .....	1
PURPOSE .....	1
THE POEO ACT PROVISIONS .....	1
LOCAL COUNCIL RESPONSIBILITY .....	1
WHAT IS THE CODE? .....	1
IS THE CODE COMPULSORY? .....	1
THE CODE .....	1
BEST PRACTICE GUIDE FOR NOISE MANAGEMENT OF ON-FARM PROCESSING OF MACADAMIA NUTS .....	3
<b>APPENDIX A: RATIONALE FOR VOLUNTARY CODE OF PRACTICE FOR NOISE MANAGEMENT FROM ON-FARM PROCESSING OF MACADAMIA NUTS.....</b>	<b>A1</b>
1. NOISE CRITERIA .....	A1
1.1 OFFENSIVE NOISE.....	A1
1.2 ‘BACKGROUND PLUS’ CRITERIA .....	A2
1.3 FIXED VALUE CRITERIA .....	A2
2. OCCUPATIONAL HEALTH AND SAFETY – HEARING PROTECTION.....	A4
3. OFFENSIVE NOISE – WORKPLACE NOISE (OH&S) .....	A5
3.1 HOW MUCH NOISE IS TOO MUCH? .....	A5
4. NOISE CONTROL TECHNIQUES .....	A5
4.1 NOISE SOURCE IDENTIFICATION AND DIAGNOSTICS.....	A6
4.2 FUNDAMENTAL NOISE CONTROL TECHNIQUES .....	A7
<b>APPENDIX B: SUMMARY OF RESPONSIBILITIES FOR NOISE MANAGEMENT OF ON-FARM PROCESSING OF MACADAMIA NUTS.....</b>	<b>B1</b>
<b>APPENDIX C: GLOSSARY OF FREQUENTLY USED TERMS WITH LAY AND SCIENTIFIC DEFINITIONS.....</b>	<b>C1</b>
<b>APPENDIX D: CASE STUDIES ON NOISE PROBLEMS.....</b>	<b>D1</b>
<b>ATTACHMENT 1: THE POEO ACT PROVISIONS.....</b>	<b>1</b>

---

## List of Tables

	<u>page</u>
Table 1 - WHO Community Noise Guidelines .....	A33
Table 2 – Noise Sources .....	A77

---

## List of Figures

	<u>page</u>
Figure 1 – An Application of Acoustic Absorbent .....	A8
Figure 2 - Acoustic Absorbent Performance based on ‘Pyrotek Sound Sorber’ with Metallised Film...	A9
Figure 3 – Common Construction Materials: With Good Sound Insulation Performance .....	A10
Figure 4 – Common Construction Materials: With Poor Sound Insulation Performance .....	A10
Figure 5 – The Effects of Openings in Acoustic Insulation.....	A11
Figure 6 – The Principle Uses of Acoustic Absorbent and Insulation .....	A1212
Figure 7 - Elevation to Illustrate the Acoustic Barrier Design Principle: The Source and Receiver are at a Distance of ‘a’ metres apart.....	A1212
Figure 8 - Elevation to Illustrate the Acoustic Barrier Design Principle: The Source and Receiver are at a Distance of ‘b’ + ‘c’ metres apart. ....	A1212
Figure 9 - Plan View to Illustrate the Acoustic Barrier Design Principle : The Source and Receiver are at a Distance of ‘d’ + ‘e’ metres apart.....	A1214
Figure 10 - Effective Damping of Vibration in Sheet Metal Structures .....	A13
Figure 11 - Vibration Isolation Theory .....	A1417
Figure 12 - The Transmissibility Curve: Vibration Amplification (or Attenuation) with the Ratio of Forcing Frequency to Natural Frequency ( $f_r/f_n$ ).....	A1518
Figure 13 - The Rights and Wrongs of Fan Installation.....	A1619

---

## List of Abbreviations

AMS – Australian Macadamia Society Limited
ARA – Appropriate Regulatory Authority
DLWC – Department of Land & Water Conservation
EPA - Environmental Protection Authority
INP – NSW EPA Industrial Noise Policy
LCC – Lismore City Council
LLC – Lismore Living Centres
NIS – Nut-in-shell
NOHSC –National Occupational Health and Safety Commission
OH&S – Occupational Health and Safety
POEO – Protection of the Environment Operations Act

# CODE OF PRACTICE FOR NOISE MANAGEMENT OF ON-FARM PROCESSING OF MACADAMIA NUTS

## *"A GOOD NEIGHBOUR POLICY"*

This Code of Practice has been published to assist macadamia growers, their families, employees and contractors, rural residents, equipment and machinery manufacturers and other stakeholders to develop and implement practices to manage and control noise generated by stationary or fixed equipment used for on-farm macadamia nut processing. It provides best practice advice and guidance for the control of noise impacts on neighbours as well as occupational health and safety protection of hearing in the processing facility.

### Purpose

This Code provides practical guidance on complying with the NSW *Protection of the Environment Operations (POEO) Act 1997* and associated regulations in relation to noise emission from processing facilities and its effect on rural neighbours and the NSW Occupational Health and Safety Regulations.

### The POEO Act Provisions

The POEO Act which came into force in 1999, is the responsibility of the EPA. Under the powers delegated by the EPA to the Appropriate Regulatory Authority (Lismore City Council et al), there are a range of enforcement actions when an unacceptable level of noise has been emitted. Details of these have been included in Attachment 1.

### Local Council Responsibility

Under the Act a local Council has the responsibility for managing and regulating neighbourhood noise as well as noise aspects for most industrial and commercial developments.

If Council receives a complaint and a noise assessment determines that offensive noise emissions are occurring, the response of Council is to issue either a prevention control or noise control notice under the provisions of the POEO Act. Failure to comply can result in prosecution and the imposition of severe financial penalties.

### Is the Code Compulsory?

The Code is **voluntary**, and is aimed at ensuring that macadamia farming promotes a "Good Neighbour Policy" between growers, their neighbours and the community. It recognises the right of macadamia nut growers to make their own business decisions, provided these decisions comply with legal requirements, regulations and industry standards. These decisions should also comply with principles of preserving natural resources and there are no '*adverse on-site and off-site impacts on the environment and any other sector of the community*'.

It is recommended that every rural landholder take this Code into account because it is likely that following these guidelines will result in less risk of prosecution, more profitable farming activities and good neighbourly relations.

### The Code

The Code for Noise Management of On-farm Processing of Macadamia Nuts has the following noise criteria for different times of the day (i.e., day, evening and night) when measured 1.5 metres from the external wall of the nearest habitable room of the affected residence:

Time of Day	Maximum dBA
<b>Daytime</b> Mon-Fri. 6.00am to 8.00pm Sat-Sun. 7.00am to 7.00pm	50
<b>Evening</b> Mon-Fri. 8.00pm to 10.00pm Sat-Sun. 7.00pm to 10.00pm	45
<b>Night</b> Mon-Fri. 10.00pm to 6.00am (7.00am if following day Sat or Sun.) Sat-Sun. 10.00pm to 7.00am (6.00am if following day is Mon.)	40

If the noise level exceeds the above criteria, advice should be sought on mitigation methods, preferably at source. Noise limits are enforceable by Council which is the appropriate regulatory authority (ARA) under the Protection of the Environment (POEO) Act, which came into force in 1999.

It is essential that the farm managers maintain a good relationship with local residents in the interests of establishing and maintaining a 'good neighbour policy'. Where reasonably practicable this should include ensuring that local residents are fully informed about where noise creating facilities are to be constructed, and noisy operations which are likely to occur, including times when the noise

events will finish. This is particularly important for any noisy night-time work which may be required. When this situation arises, this information should be provided well in advance of the proposed event and the times given must then be strictly adhered to.

If people are informed of the times that adverse events will start and finish, their stress, and hence complaints, are significantly reduced (predictability). In addition, a contact phone number should be given to local residents (controllability). Should a complaint occur it is imperative that the complainant is treated with the utmost courtesy even if they appear to be stressed. All reasonably practicable steps should be taken to stop the noise or reduce the noise in the event of complaint. If it is not practicable to stop the noise, or reduce the noise, a full and fair explanation of the job being undertaken and the reason for the noise should be given to the complainant.

**Talk to your neighbours  
before a problem is  
created**

The following best practice guide table provides the best practice actions (with explanations) which address a range of issues related to noise production with on-farm nut processing facilities. This table identifies the issue or the problem, the recommended best practice action, along with a commentary. This is followed by a number of supporting documents, namely:

- Appendix A contains the detailed technical information on which the voluntary code of practice is based. This appendix discusses the noise criteria, occupational health and safety aspects, what is offensive noise and noise control techniques.
- Appendix B summarises the responsibilities of stakeholders for noise management (ie grower; machinery/equipment manufacturers; Council; and residents/neighbours).
- Appendix C contains a glossary of frequently used terms with lay and scientific definitions.
- Appendix D contains selected case studies to illustrate noise problems. These are actual examples of both good and bad farm practices which demonstrate the importance of sound

planning and the use of expert advice and communication.

- Attachment 1 at the end of the document contains information about the POEO Act and the range of noise enforcement actions available.

## BEST PRACTICE GUIDE FOR NOISE MANAGEMENT OF ON-FARM PROCESSING OF MACADAMIA NUTS

### 'A GOOD NEIGHBOUR POLICY'

ISSUE/PROBLEM	RECOMMENDED BEST PRACTICE ACTION	EXPLANATION/COMMENTARY
<b>1. ESTABLISHING A NEW DE-HUSKING FACILITY</b> ( <i>see also Appendix A, Section 4, ppA5-A16</i> )		
<b>1.1 Prepare a plan</b>	<ul style="list-style-type: none"> <li>▪ Develop a complete detailed plan for the establishment of a de-husking facility to ensure that it complies with all local government regulations, and is able to operate at maximum efficiency to meet your design criteria for the orchards output.</li> <li>▪ Identify a site to locate the de-husking facility that maximises the distance from the closest residence while accounting for operational requirements such as power, vehicle access etc.</li> </ul>	<ul style="list-style-type: none"> <li>▪ The first step for the grower when developing a new on-farm nut processing facility, or upgrading an existing facility is to prepare a plan.</li> <li>▪ A plan ensures that all issues are considered, including regulatory, environmental (eg, noise), location, residential neighbours, construction, utility services (eg, 3-phase power), positioning, construction cost, operational costs and human resources.</li> <li>▪ Careful planning is an essential part of any installation, which has the potential for noise emissions into the local community.</li> <li>▪ A significant reduction in potential noise problems can be achieved by ensuring that de-husking facilities are placed as far as possible from the nearest neighbour. (See Appendix D case study where this has been an issue)</li> </ul>
<b>1.2 Noise impact assessment</b>	<ul style="list-style-type: none"> <li>▪ New macadamia nut processing facilities or additions to existing facilities should have a noise impact assessment carried out by competent and qualified persons or organisations.</li> </ul> <p>(<i>see also Issue/Problem 2.3</i>).</p>	<ul style="list-style-type: none"> <li>▪ The noise assessment sets criteria and predicts noise levels at the nearest residential receiver positions. This would be based mainly on the source noise levels, the distance from the source to the receiver and the terrain. If the predicted noise level exceeds the criteria, a noise consultant can provide advice on mitigation methods, preferably at source. Mitigation could include, for example, improving sound proofing of the de-husking enclosure and the silencers or attenuators of the fans.</li> <li>▪ Professional bodies such as the Australian Acoustical Society (AAS) (Tel: 03 9887 9400) and the Association of Australian Acoustical Consultants (AAAC) (Tel: 02 9331 6920) have members with degree level qualifications in acoustics and many years experience in accurately assessing noise impacts.</li> <li>▪ In many cases the consultancy costs may not be high, and are generally significantly less than retrofitting noise control systems after the installation is completed.</li> </ul>

ISSUE/PROBLEM	RECOMMENDED BEST PRACTICE ACTION	EXPLANATION/COMMENTARY
<b>1.3 Regulatory and compliance aspects</b>	<ul style="list-style-type: none"> <li>▪ The plan should cover the following:               <ul style="list-style-type: none"> <li>- a list of local and State statutory requirements and clearances (eg, buffer zone, operating noise levels and hours, appropriate land title, land use restrictions);</li> <li>- evidence that the proposed processing facility and associated silo drying fans can be operated within all relevant laws;</li> <li>- evidence of compliance with local and state guidelines for noise levels;</li> <li>- approval process, if relevant and the time it requires;</li> <li>- land ownership rights;</li> <li>- location of property;</li> <li>- property plan; and</li> <li>- existing infrastructure, roads, lanes, electricity (whether 2-phase or 3-phase) and buildings.</li> </ul> </li> </ul>	<ul style="list-style-type: none"> <li>▪ During harvesting operations, de-husking plants may generate significant levels of noise and traffic which can have impacts on adjoining properties. For this reason proposals for new dwellings on properties adjoining existing macadamia de-husking plants should be located as far as practical from the processing facility. In order to minimise adverse impacts a minimum buffer of 300 metres is recommended for new residential development, although this may be more or less depending on an assessment of such factors as the degree of noise attenuation already achieved by nut processing machinery.</li> <li>▪ While the construction of a shed to house processing equipment and plant or the modification of an existing shed situated on agricultural land may not require a Development Application (DA) from the local council, (unless it is to be used to process macadamia nuts from other farms) it is essential that all regulatory and compliance issues are identified and met as necessary.</li> </ul>
<b>1.4 Designing a de-husking facility</b>	<ul style="list-style-type: none"> <li>▪ The design and choice of the nut processing plant and equipment should take into account different factors and constraints including:               <ul style="list-style-type: none"> <li>- proposed location;</li> <li>- human resources to operate it efficiently and correctly;</li> <li>- occupational health and safety issues;</li> <li>- legal and regulatory requirements;</li> <li>- expansion strategy;</li> <li>- flexibility of use;</li> <li>- automation; and</li> <li>- investment required to install the equipment or to construct, operate and maintain the facility selected and cost comparison with other facilities with or without noise attenuation.</li> </ul> </li> </ul>	<ul style="list-style-type: none"> <li>▪ The detailed design and choice of de-husking facility (shed, processing and storage equipment) is a key element in noise management to meet the processing requirements of the current and future output of an orchard. This applies equally to new or second-hand components.</li> <li>▪ Manufacturers of buildings, plant and equipment should be able to demonstrate their competence to undertake the tasks and that they can meet the necessary equipment specifications.</li> </ul>
<b>1.4.1 Environmental aspects</b>	<ul style="list-style-type: none"> <li>▪ Environmental areas should be identified and addressed. These can include:               <ul style="list-style-type: none"> <li>- condition of natural watercourses that might be used for drainage discharge or as a source of water; and</li> <li>- distance from settlements and rural residents that could be affected</li> </ul> </li> </ul>	<ul style="list-style-type: none"> <li>▪ Recognising potential environmental issues at the planning stage can avoid the need to expend scarce resources to eliminate a problem in the future</li> </ul>

<sup>1</sup> Development Control Plan No. 27 – Buffer Areas, 19 February 1994, Lismore City Council, Section 3.2.



ISSUE/PROBLEM	RECOMMENDED BEST PRACTICE ACTION	EXPLANATION/COMMENTARY
1.4.2 Buffer zone	<p>by the operation of the processing facility.</p> <ul style="list-style-type: none"> <li>▪ The recommended minimum buffer zone from a residential dwelling or development is 300 metres should be taken into consideration.</li> </ul>	<ul style="list-style-type: none"> <li>▪ Important for residential dwellings to be located as far as practical from the processing facility to minimise adverse impacts.</li> <li>▪ During harvesting operations de-husking plants and drying fans may generate significant levels of noise and traffic which can have impacts on adjoining properties</li> </ul>
1.4.3 Detailed design	<ul style="list-style-type: none"> <li>▪ The detailed design should include: <ul style="list-style-type: none"> <li>- physical layout including operational flow;</li> <li>- specification of components and their installation;</li> <li>- operating schedule of the facility and any constraints;</li> <li>- degree of automation;</li> <li>- energy requirements and energy source;</li> <li>- estimated life of facility (according to manufacturer's specifications);</li> <li>- detailed costing of components and labour required to install, operate and maintain the facility;</li> <li>- potential for staged development and order of construction; and</li> <li>- commissioning procedures.</li> </ul> </li> </ul>	<ul style="list-style-type: none"> <li>▪ It is worthwhile obtaining the services of a designer to specify the exact requirements for an efficient operation.</li> </ul>
1.5 Equipment installation and commissioning	<ul style="list-style-type: none"> <li>▪ It is essential that all equipment should be installed and operated in the way in which it has been designed.</li> <li>▪ During installation the grower or other responsible person should perform an on-going audit to ensure all design specifications and regulations are met. The following checks should be made: <ul style="list-style-type: none"> <li>- whether all components meet appropriate product standards; and</li> <li>- whether all construction complies with all regulations, including engineering design specifications, environmental and occupational, health and safety requirements.</li> </ul> </li> <li>▪ Following completion of the installation the contractor should provide a complete record of work that includes: <ul style="list-style-type: none"> <li>- a commissioning report;</li> <li>- written operating instructions and manuals;</li> <li>- an accurate plan of the facility as built; and</li> <li>- maintenance schedule for the proper maintenance of all installed equipment and associated silo drying fans.</li> </ul> </li> </ul>	<ul style="list-style-type: none"> <li>▪ This requires close cooperation between the orchard manager, designer and the contractors installing the facility. It is in the best interests of all parties to ensure that an appropriate contract is prepared.</li> <li>▪ If necessary, the contractor should arrange for the training of key staff to ensure correct operation of all components of the processing facility or of the new or second-hand component(s) installed.</li> </ul>

ISSUE/PROBLEM	RECOMMENDED BEST PRACTICE ACTION	EXPLANATION/COMMENTARY
<b>1.6 Equipment operation and maintenance</b>	<ul style="list-style-type: none"> <li>▪ Correct operation and maintenance of a processing facility and silo drying fans require an understanding of basic principles:               <ul style="list-style-type: none"> <li>- regular service of parts and equipment as per schedule;</li> <li>- regular maintenance checks of all physical parts of the facility to check for wear and tear, particularly those surfaces exposed to moving nuts;</li> <li>- schedule of maintenance;</li> <li>- correctly trained staff to operate the facility;</li> <li>- detailed instructions for the correct operation of the facility;</li> <li>- working life of components; and</li> <li>- redevelopment/upgrading plan.</li> </ul> </li> </ul>	<ul style="list-style-type: none"> <li>▪ Management, operation and maintenance of the installed processing facility are the key to cost-effective operation. A facility that has been either designed and built as a noise attenuated facility or where noise attenuation work has been carried out on a component, must be operated correctly if it is to achieve its noise reduction efficiency.</li> </ul>
<b>1.6.1 Operator's skills</b>	<ul style="list-style-type: none"> <li>▪ Once the processing facility or any new additions to the facility have been commissioned and handed over by the installer, the responsibility for ongoing operation and maintenance lies with the grower. Staff should be able to demonstrate the following skills:               <ul style="list-style-type: none"> <li>- basic knowledge of the facility components and their function;</li> <li>- read plans, manuals and technical specifications;</li> <li>- test nut throughput rates;</li> <li>- monitor component performance, including alignment and efficiency;</li> <li>- monitor and maintain noise-treated surfaces;</li> <li>- basic knowledge of facility repairs;</li> <li>- an understanding of how to operate the facility safely within OH&amp;S regulations;</li> <li>- keep records;</li> <li>- understand operational risks; and</li> <li>- determine the potential for off-site impacts (eg, noise) from operation of the processing facility and silo drying fans.</li> </ul> </li> </ul>	<ul style="list-style-type: none"> <li>▪ The grower should ensure that key staff are familiar with the correct operation of all components of the processing facility or of the new or second-hand component(s) installed and the potential for off-site impacts (eg, noise) from operation of the processing facility and silo drying fans.</li> </ul>
<b>1.6.2 Human resource issues</b>	<ul style="list-style-type: none"> <li>▪ Controlling of noise at source leads to better and safer working conditions.</li> </ul>	<ul style="list-style-type: none"> <li>▪ The number of people who will be required to work in the processing facility and the noise attenuation strategy need to meet WorkCover OH&amp;S requirements.</li> <li>▪ For advice on work place issues, employers or employees should contact WorkCover NSW (Tel: 131 050).</li> <li>▪ Noise levels near to the de-husking operation in macadamia nut</li> </ul>

ISSUE/PROBLEM	RECOMMENDED BEST PRACTICE ACTION	EXPLANATION/COMMENTARY
		<p>processing operations are likely to be the cause of exposures over (<math>L_{Aeq, 8 \text{ hr}}</math>) 85dBA.</p> <ul style="list-style-type: none"> <li>▪ Reduction of noise problems at source also reduces the level of noise being transmitted externally from the processing facility.</li> <li>▪ Noise exposure levels above an eight-hour equivalent of 80dBA require the use of hearing protection and (<math>L_{Aeq, 8 \text{ hr}}</math>) 85dBA is a legal limit for exposure.</li> </ul>
<p><b>1.6.3 Operating and maintenance documentation</b></p>	<ul style="list-style-type: none"> <li>▪ The facility maintenance manual should include: <ul style="list-style-type: none"> <li>- a service manual and parts book; and</li> <li>- a schedule of maintenance and replacement that specifies the frequency of inspection and service for all elements of the facility.</li> </ul> </li> <li>▪ Maintenance records as well as financial records of costs to operate and maintain the facility should be kept.</li> <li>▪ The operation manual should specify: <ul style="list-style-type: none"> <li>- the correct way to operate all equipment and auxiliary components;</li> <li>- how the system should work and its optimal operating throughput;</li> <li>- protocols for operating the facility safely;</li> <li>- how the facility's operation will be monitored; and</li> <li>- how environmental impacts such as noise will be monitored</li> </ul> </li> </ul>	<ul style="list-style-type: none"> <li>▪ The facility should have both an operation manual and a maintenance manual.</li> </ul>
<p><b>1.7 Maintaining community relations</b></p>	<ul style="list-style-type: none"> <li>▪ Ensure local residents are fully informed about where noise creating facilities are to be constructed, and noisy operations which are likely to occur, including times when noise events will finish.</li> <li>▪ Maintain a good relationship with local residents in the interests of establishing and maintaining a <i>'good neighbour policy'</i>.</li> <li>▪ Where reasonably practicable ensure that local residents are fully informed about where noise creating facilities are to be constructed, and noisy operations which are likely to occur, including times when the noise events will finish. This is particularly important for any noisy night-time work which may be required. This information should be provided well in advance of the proposed event and the times given must then be strictly adhered to.</li> <li>▪ In addition, a contact phone number should be given to local residents</li> </ul>	<ul style="list-style-type: none"> <li>▪ Particularly important for any noisy night-time work which may be required.</li> <li>▪ If people are informed of the times that adverse events will start and finish, the stress, and hence complaints, are significantly reduced (predictability).</li> </ul>

ISSUE/PROBLEM	RECOMMENDED BEST PRACTICE ACTION	EXPLANATION/COMMENTARY
	<p>(controllability).</p> <ul style="list-style-type: none"> <li>▪ Should a complaint occur it is imperative that the complainant is treated with the utmost courtesy even if he/she appear to be stressed.</li> <li>▪ All reasonably practicable steps should be taken to stop the noise or reduce the noise in the event of complaint. If it is not practicable to stop the noise, or reduce the noise, a full and fair explanation of the job being undertaken and the reason for the noise should be given to the complainant.</li> </ul>	
<b>1.8 Planning and community relations</b>	<ul style="list-style-type: none"> <li>▪ Council and growers have a responsibility to inform people likely to be affected by noise if they are intending to purchase rural land or become tenants in rural residential areas</li> </ul>	<ul style="list-style-type: none"> <li>▪ Helps maintain a good relationship with local residents in the interests of establishing and maintaining a 'good neighbour policy'.</li> </ul>
<b>1.8.1 Intending purchasers – Council responsibility</b>	<ul style="list-style-type: none"> <li>▪ Council should provide a note on the Section 149 Certificate or such other measure as they may wish to take, indicating that these activities are legitimate rural and agricultural uses of rural land where such activities or uses are carried out in accordance with this Code, industry standards, relevant regulations and approvals.</li> </ul>	<ul style="list-style-type: none"> <li>▪ Talk to intending neighbours before a problem is created</li> <li>▪ The local Council should advise intending purchasers of rural land of the potential for on-farm activities within the area, in particular those activities associated with the on-farm processing and drying of macadamia nuts and routine spraying activities which are part of normal orchard management within this Code.</li> </ul>
<b>1.8.2 Tenants in rural residential areas</b>	<ul style="list-style-type: none"> <li>▪ Landlords should advise intending tenants of dwellings located in the vicinity of macadamia orchards of the type and nature of on-farm activities which will take place during the period of their tenancy.</li> <li>▪ Tenants should be made aware of what activities are legitimate agricultural uses of rural land by macadamia growers where such activities or uses are carried out in accordance with this Code of Practice, industry standards, relevant regulations and approvals.</li> </ul>	<ul style="list-style-type: none"> <li>▪ Talk to intending neighbours before a problem is created</li> </ul>
<b>1.9 Hours of operation</b>	<ul style="list-style-type: none"> <li>▪ Processing operations should be planned to achieve agreed noise levels during day-time, evening and night-time.</li> <li>▪ Strict adherence to processing hours is essential.</li> </ul>	<ul style="list-style-type: none"> <li>▪ This will reduce potential noise nuisance affecting neighbours.</li> </ul>

ISSUE/PROBLEM	RECOMMENDED BEST PRACTICE ACTION	EXPLANATION/COMMENTARY
<b>2. OPERATING AN EXISTING DE-HUSKING FACILITY – NOISE MANAGEMENT</b> ( <i>see also Appendix A, Section 4, ppA5-A16</i> )		
<b>2.1 Allegation of offensive noise</b>	<ul style="list-style-type: none"> <li>▪ The alleged source of noise should be identified and discussed with neighbour who is responsible for the operation of the plant or equipment causing the offensive noise.</li> <li>▪ If problem persists, the local Council (eg, Lismore City Council: Environmental Health &amp; Building Department, Tel: 02 6625 0500) should be contacted.</li> </ul>	<ul style="list-style-type: none"> <li>▪ A local Council is an independent regulator under legislation which came into force in 1999, namely the Protection of the Environment Operations (POEO) Act. Under this Act Councils are the appropriate regulatory authority (ARA) for managing and regulating neighbourhood noise as well as noise aspects for most industrial and commercial developments.</li> <li>▪ It is up to the local Council as to what guidelines they adopt in relation to noise performance targets and in doing this they act as a 'reasonable person' in balancing the expectations of all interested parties.</li> </ul>
<b>2.2 Noise problem</b>	<ul style="list-style-type: none"> <li>▪ If there is an alleged noise problem the source of the noise should be identified by the grower steps taken to eliminate or reduce the noise to a level which does not exceed the noise criteria.</li> </ul>	<ul style="list-style-type: none"> <li>▪ Noise levels from an existing on-farm processing of macadamia nuts exceed the noise criteria</li> </ul>
<b>2.2.1 Identifying sources of noise</b>	<ul style="list-style-type: none"> <li>▪ To solve any noise problem the following needs to be established: <ul style="list-style-type: none"> <li>(i) Source (i.e., where the noise comes from) - In identifying the noise problem, it is important to consider carefully the source of the noise and the path the noise takes from source to receiver. For example, a tractor generates noise when the motor is running. However, tractors also radiate clutch and gear noise, and vibration. (<i>See also Appendix D Section 4 - Noise Control Techniques</i>).</li> <li>(ii) Pathways (i.e., how the noise is conveyed to the receiver) - Noise from individual sources may reach the receiver by different pathways. Some will travel through the machine frame and floor as mechanical vibrations. These vibrations will eventually reach the operator and neighbours as noise radiated from floors and walls.</li> </ul> </li> </ul>	<ul style="list-style-type: none"> <li>▪ Identify exact cause of noise (i.e., noise diagnostics).</li> <li>▪ Needs to be done before noise control solutions are even considered.</li> </ul>
<b>2.3 Noise assessment</b>	<ul style="list-style-type: none"> <li>▪ Should be carried out by a person who has received training and is competent to carry out noise measurements</li> <li>▪ Assessment should be repeated at intervals not exceeding five years or</li> </ul>	<ul style="list-style-type: none"> <li>▪ The general objectives of noise assessments are to: <ul style="list-style-type: none"> <li>- obtain information on noise sources and work practices that will help growers and machinery/equipment manufacturers to decide what</li> </ul> </li> </ul>

ISSUE/PROBLEM	RECOMMENDED BEST PRACTICE ACTION	EXPLANATION/COMMENTARY
	whenever there is <ul style="list-style-type: none"> <li>- installation or removal of machinery; and</li> <li>- a change in workload or equipment operating conditions likely to cause a significant change in noise levels.</li> </ul> <ul style="list-style-type: none"> <li>▪ Noise assessment records should be made in a consistent format and made available to employers, management, employee representative(s) and relevant authorities. (see also Issue/Problem 1.2)</li> </ul>	measures should be taken to reduce noise; and <ul style="list-style-type: none"> <li>- check the effectiveness of measures taken to reduce exposure.</li> </ul> <ul style="list-style-type: none"> <li>▪ There is a great deal more involved than just reading the results from the sound level meter display panel. Professional bodies such as the Australian Acoustical Society (AAS) (Tel: 02 9331 6920) and the Association of Australian Acoustical Consultants (AAAC) (Tel: 07 3367 3131) for example, have members who are competent and have many years experience in carrying out noise measurements.</li> </ul>
2.4 Controlling noise	<ul style="list-style-type: none"> <li>▪ Once the main noise sources are known, control measures must be introduced. There are two main options:               <ul style="list-style-type: none"> <li>- eliminate or modify the noise source; and</li> <li>- stop the noise from being transmitted.</li> </ul> </li> <li>▪ The most effective approach for controlling noise is through the reduction of noise at source. The <b>management hierarchy for controlling noise</b> is provided below. in sections 2.4.1 to 2.4.4</li> </ul>	<ul style="list-style-type: none"> <li>▪ A noise management policy and guidelines should be established. The responsibility of implementing the policy should reside with the grower or farm manager.</li> </ul>
2.4.1 Controlling noise - purchase of "quieter" equipment	<ul style="list-style-type: none"> <li>▪ Whenever equipment is to be replaced select items which have the lowest noise rating.</li> </ul>	<ul style="list-style-type: none"> <li>▪ There should be a clearly identifiable label placed in a prominent position on the machinery by the manufacturer which indicates the decibel level or noise intensity of the implement.</li> </ul>
2.4.2 Controlling noise - engineering noise control	<ul style="list-style-type: none"> <li>▪ If it is not possible to get rid of the source of the noise (eg, disposing of machinery), try insulating the machinery or the area in which it operates (eg, addition of noise barriers, noise enclosures, isolating vibration sources, absorbing shocks such as nut on metal through the provision of wear-resistant rubber or plastic coatings on impact surfaces, minimising the fall height onto hard surfaces of nuts collected by sorting tables and bins and silos during processing or augering).</li> </ul>	<ul style="list-style-type: none"> <li>▪ There are several simple ways by which noise levels may be reduced, including the regular inspection and maintenance of machinery to detect loose brackets, faulty mufflers, broken seals and other malfunctioning equipment, all of which increase the noise levels.</li> <li>▪ Some common use materials are excellent for sound insulation and sound barriers and some are extremely poor. See Figures 3 and 4 in Appendix A</li> </ul>
2.4.3 Controlling noise - administrative noise control	<ul style="list-style-type: none"> <li>▪ Introduce measures that reduce the noise (eg, reduce the number of processes in operation at one time) or the time of operation of the equipment (eg, scheduling of the processing operation).</li> </ul>	<ul style="list-style-type: none"> <li>▪ A low cost management response which may eliminate the problem depending on the source of the noise.</li> </ul>
2.4.4 Controlling noise – personal hearing protectors	<ul style="list-style-type: none"> <li>▪ If the noise cannot be excluded, isolated or contained within the facility (eg, isolation by insulating the de-husker or the hammer mill) it will be necessary to use a combination of control measures which can include the use of personal hearing protectors.</li> </ul>	<ul style="list-style-type: none"> <li>▪ See also WorkCover - Codes of Practice, 1996</li> </ul>

ISSUE/PROBLEM	RECOMMENDED BEST PRACTICE ACTION	EXPLANATION/COMMENTARY
2.5 Noise Measurements	<ul style="list-style-type: none"> <li>▪ The instrumentation used for environmental and occupational noise assessments must conform to Australian Standard 1259 "Acoustics - Sound Level Meters", (1982 [or updated equivalent Standard]) as a Type 1 precision or a Type 2 sound level meter and have an accuracy suitable for both field and laboratory use.</li> <li>▪ The calibration of the meter must be checked before and after the measurement period with a Type 1 acoustical calibrator. If any significant system drift occurs over the measurement period(s) this must be reported.</li> </ul>	<ul style="list-style-type: none"> <li>▪ The calibration of noise measuring equipment and the competency of persons conducting noise measurement are critical issues.</li> <li>▪ The sound level meter and calibrator must be checked, adjusted and aligned to conform to the manufacturers' factory specifications at least every two years and issued with a conformance certificate. The internal test equipment used must be traceable to the National Measurement Laboratory at CSIRO, Lindfield, NSW, Australia.</li> </ul>
2.5.1. Measurement Procedure	<ul style="list-style-type: none"> <li>▪ The 'free field' or 'façade' measurements should be carried out on-site at a height of approximately 1.5 metres. Free-field measurements are to be carried out at least 3.5 metres from any reflecting surface other than the ground. In general 'façade' measurements will result in a level between 2dB and 3dB higher than 'free field'. The chosen method of taking the measurements must be reported.</li> <li>▪ For all outdoor measurements a windshield, as supplied by sound level meter manufacturers, must be fitted over the microphone. The general weather conditions during the measurement period must be reported for all outdoor measurements.</li> </ul>	<ul style="list-style-type: none"> <li>▪ The 'A' frequency weighting, octave band or 1/3 octave band frequency analysis may need to be taken and the 'fast' time weighting is generally to be used.</li> <li>▪ It is generally not advisable to take sound level measurements in adverse weather conditions (i.e., wind speeds of greater than 5 metres per second or heavy rain)</li> <li>▪ It is essential that only persons, who have received training and are competent in the task, carry out noise measurements</li> <li>▪ As with planning an installation of an on-farm processing facility consultants can provide cost effective advice. Professional bodies such as the Australian Acoustical Society (AAS) (Tel: 02 9331 6920) and the Association of Australian Acoustical Consultants (AAAC), (Tel: 07 3367 3131) have members who are competent and have many years experience in carrying out noise measurements.</li> </ul>
2.6 Elimination or reduction of noise	<ul style="list-style-type: none"> <li>▪ Ideally noise should be 'designed out' at source including: <ul style="list-style-type: none"> <li>- engineering modifications that alter the process of noise generation (limited only by the experience and imagination of the engineer);</li> <li>- vibration isolation: introduce a vibration "break" to prevent the transmission of mechanical energy;</li> <li>- vibration damping: extract and dissipate the energy in vibrating surfaces;</li> <li>- silencing: for aerodynamic sources using conventional and unconventional attenuators (i.e., mufflers or "silencers");</li> <li>- sound insulation and absorption: preventing the transmission of sound</li> </ul> </li> </ul>	<ul style="list-style-type: none"> <li>▪ Emphasis on controlling noise at its source by using engineering control methods.</li> <li>▪ Engineering noise controls are more effective and more economical at the design and manufacturing stage of the process rather than after the equipment has been installed.</li> <li>▪ Acoustic absorbent materials are porous to allow sound waves to penetrate and yet dense enough to cause high viscous losses within the small air passages as the air excited by the incident sound is "pumped" backwards and forwards through them.</li> <li>▪ The effectiveness of an acoustic absorbent lining also depends on the</li> </ul>

ISSUE/PROBLEM	RECOMMENDED BEST PRACTICE ACTION	EXPLANATION/COMMENTARY
	<p>by introducing a barrier (enclosure) lined with acoustic absorbent; and - remove the noise or substitute quiet methods.</p>	<p>thickness of the absorbent material.</p> <ul style="list-style-type: none"> <li>▪ Acoustic insulation involves insulating one area from another using an insulating wall – the ideal materials are limp, massive and impermeable.</li> <li>▪ Well designed acoustic enclosures utilise sound insulation materials externally and acoustic absorbent materials internally to prevent reverberant sound build-up.</li> <li>▪ Vibration isolation involves inserting a flexible element (spring or isolator) into the system at some point (eg, air springs, metal springs, rubbers and elastomers, cork/rubber pads).</li> <li>▪ Vibration damping: thin machine panels, guards, chutes, hoppers, etc often radiate high levels of noise when subject to impacts – the damping mechanism extracts vibration energy from the thin sheet, dissipating it as heat.</li> <li>▪ Unconstrained layer damping, eg, stick-on viscoelastic or bitumastic anti-drumming panels (can wear out quickly if damping material is on same side as impacts).</li> <li>▪ Constrained layer damping, eg, rubber-bonded viscoelastic or cork gasket material sandwiched between two sheets of steel of similar material and gauge, or sound-deadened steel.</li> </ul>
2.7 Prevention of noise	<ul style="list-style-type: none"> <li>▪ Enclose or isolate the noise (or the receiver) by placing a barrier between the noise and the receiver</li> </ul>	<ul style="list-style-type: none"> <li>▪ Use of barriers, mufflers and enclosures (do not reduce the noise of the source, only stop the noise travelling from the source to receiver): <ul style="list-style-type: none"> <li>- barriers (eg, acoustic walls and fences): close to worthless if there are gaps underneath or panels are missing. Normally constructed from sound insulating materials such as brick, concrete, 'lapped and capped' wooden fences, steel sheet or earth bunds to reflect the noise away from receiver positions.</li> <li>- mufflers: performance is very poor if there are holes in the casing</li> <li>- enclosures: ineffective if panels are left open</li> </ul> </li> </ul>



ISSUE/PROBLEM	RECOMMENDED BEST PRACTICE ACTION	EXPLANATION/COMMENTARY
<b>3. RECTIFYING NOISE PROBLEMS WHEN SILO FANS ARE THE SOURCE</b> ( <i>see also Appendix A, Section 4, ppA15-A16</i> )		
<b>3.1 Fan noise control</b>	<ul style="list-style-type: none"> <li>▪ Ensure correct installation</li> <li>▪ Carry out diagnostic tests to determine the relative contributions of the aerodynamic and mechanically transmitted noise components</li> </ul>	<ul style="list-style-type: none"> <li>▪ Fans are aerodynamic noise sources which generate pressure fluctuations (sound waves) directly.</li> <li>▪ Acceptability of noise from a particular fan installation depends on whether the problem is noise nuisance (when tonal noise is particularly important) or possible hearing damage (when frequency content and absolute amplitude are important)</li> </ul>
<b>3.1.1 Elimination or reduction of fan noise</b>	<ul style="list-style-type: none"> <li>▪ Ideally noise should be 'designed out' at source, including:               <ul style="list-style-type: none"> <li>- silencing: for aerodynamic sources using conventional and unconventional attenuators (i.e., mufflers or "silencers")</li> <li>- remove the noise or substitute quiet methods</li> </ul> </li> </ul>	<ul style="list-style-type: none"> <li>▪ Should be done before choosing noise control measures</li> <li>▪ Attenuators (silencers or mufflers) can be used to reduce aerodynamic fan noise transmitted down ducts, these are either reactive, absorptive or circular, all with varying performance <i>characteristics</i> in relation to fan noise reduction</li> <li>▪ There are right and wrong ways of fan installation (<i>see Appendix A, Figure 13, page A16</i>)</li> </ul>

**APPENDIX A:  
RATIONALE FOR VOLUNTARY CODE OF  
PRACTICE FOR NOISE MANAGEMENT  
FROM ON-FARM PROCESSING OF  
MACADAMIA NUTS**

**1. Noise Criteria**

Noise criteria are a general set of non-mandatory noise level targets for the protection of receivers against intrusive noise and the loss of amenity. Noise limits are enforceable noise levels that appear in conditions on consents and licences. The noise limits are based on achievable noise levels, which the proponent has predicted can be met during an environmental assessment. Exceeding the noise limits can result in the requirement for either the development of noise management plans to reduce the noise within a given timeframe or for legal action.

There are no easy methods of setting noise criteria, as the criteria need to be objective for offensive noise, which is inherently subjective. There are two common approaches for setting noise criteria for offensive noise. One method is to set a sound pressure level when measured in decibels which is dependant upon the existing background noise level (commonly known as 'background plus'). The other method is to set a certain fixed value of sound pressure level, which is usually based on social surveys, empirical data and achievable noise levels. Both methods have advantages and disadvantages and both methods are used concurrently for different applications in most countries of the world.

**1.1 Offensive Noise**

The object of any noise criteria is to eliminate or at least minimise the level of offensive noise at neighbouring receiver points. The NSW *Protection of the Environment Operations (POEO) Act 1997* (and similarly the QLD *Environmental Protection Act 1994*) defines offensive noise as noise that:

- (a) by reason of its level, nature, character or quality, or time at which it is made, or any other circumstances:
  - i. is harmful to (or is likely to be harmful to) a person who is outside the premises from which it is emitted, or
  - ii. interferes unreasonably with (or is likely to interfere unreasonably with) the comfort or repose of a person who is outside the premises from which it is emitted, or
- (b) is of a level, nature, character or quality prescribed by the regulations or that is made at a time, or in any circumstances prescribed by the regulations.

It is clearly recognised that it is not just the sound pressure level, the loudness or the volume of sound that can create offensive noise. In fact, as the loudness becomes less, the character of any audible noise becomes more dominant in the noise annoyance perception and the sound pressure level (particularly the 'A' frequency weighted sound pressure level) becomes almost immaterial.<sup>2</sup>

Although offensive noise is subjective, it is necessary to establish objective criteria to enable a consistent approach to the investigation of noise complaints. This mainly involves the use of acoustical instrumentation (sound level meters) to accurately (i.e., within +/- 2dB) measure the offensive noise using the decibel scale and then make adjustments. The adjustments are to allow for the character of the offensive noise and the subtraction of any extraneous noise, which in many cases is not possible to directly exclude from the measurement process. The adjusted level is used to compare against the noise criteria.

---

<sup>2</sup> See for example '*Human Response to a Low Frequency, Repetitive Impulse Noise*'. Journal of Low Frequency Noise and Vibration, Volume 8 Number 4 1989, UK ISSN 0263-0923.

In the animal kingdom a loud noise signifies danger. Our bodies are geared to increase blood pressure and heart rate in the presence of sudden or high noise levels. This is an involuntary reaction and causes stress. Prolonged exposure to perceived offensive noise commonly has two very different effects on different people: a reduction in stress with time (psychological adaptation) or an increase in stress with time (psychological sensitisation). Human response to all sensory stimuli is highly variable and the response to noise is no exception. What is important is that all of the wide-ranging responses are 'normal'. There seems to be at least two main types of reaction. Some people 'learn to live with the noise' and gradually adapt to it, and other people becomes progressively more disturbed by it and could be said to be sensitive to noise.

In summary, there is nothing extraordinary about people becoming highly stressed by the presence, in their own home, of low-level noise that is audible. This particularly occurs when that noise is unwanted, uncontrollable, of an unpleasant character and when the home provides no refuge from it. The wide range of human reactions to noise makes the setting of reasonable criteria particularly difficult.

### 1.2 'Background Plus' Criteria

The perception of noise and its level of offensiveness depend greatly on the broader situation within which it occurs. Noise that might intrude into a resting or sleeping place may be found to be offensive whereas the same noise occurring in a market place or noisy working area may pass unnoticed. This is because the noise may be masked by other less intrusive sounds. The commonly quoted and applied concept of '*background + 5dB*' derives from this consideration. The *background + 5dB criterion* has no scientific basis and it is not based on any substantive research. It is likely that the concept was conceived in the UK in the early 1960s based on

accumulated experience of a few practitioners. It first appeared in the British Standard BS 4142: 1967.<sup>3</sup> The current British Standard BS 4142: 1997 states that a difference between the source noise (character adjusted) and the background of +10dB or more, indicates that complaints are likely and a difference of around +5dB has a marginal impact.

It is thought that the '*background + 5dB*' used in Australia and specifically quoted in the NSW EPA Industrial Noise Policy (2000)<sup>4</sup> originates from the British Standard 4142.

### 1.3 Fixed Value Criteria

Many organisations recommend fixed value criteria. This has the advantage of not requiring the background level to be assessed. Measuring background levels can be long-winded, difficult and expensive; and lead to disagreements. Fixed values give manufacturers of noise producing equipment a clearer understanding of noise goals. However, fixed values have the disadvantage of not utilising the potential sound masking effect of the existing background. Some of the organisations who recommend the application of fixed value criteria are outlined below.

A further issue involves 'background creep' where the effect of two or more de-husking operations impacts on a residence. If the de-husking operations are the same distance away from a receiver the second de-husking shed would need to be 10dB less than the first one to give an overall increase of less than 0.5dB. The use of a background plus 5dB criterion has the same difficulty.

<sup>3</sup> British Standard BS 4142 'Method for Rating industrial noise affecting mixed residential and industrial areas', 1967.

<sup>4</sup> Originally quoted in the EPA's Environmental Noise Control Manual (formerly endorsed by the State Pollution Control Commission on 24 May 1985, the final update in 1994 and it was made obsolete in 2000)

1.3.1 *World Health Organisation*

The World Health Organisation (WHO) offer guidelines and recommendations to governments for implementing noise goals. This includes community noise in environmental impact assessments. These guidelines ( $L_{Aeq}$ )<sup>5</sup> are shown in Table 1 below.

**Table 1 - WHO Community Noise Guidelines**

Environ-ment	Critical Health Effect	Sound Pressure Level (dBA)	Time (hours)
Outdoor living areas	Annoyance	50 - 55	16
Indoor dwellings	Speech intelligibility	35	16
Bedrooms	Sleep disturbance	30	8
Industrial, commercial & traffic areas	Hearing impairment	70	24

1.3.2 *Griffith City Council and Leeton Shire Council*

Griffith City Council and Leeton Shire Council have produced a 'Draft Frost Control Fan Policy' (September 2000). The policy gives outdoor night time noise criteria ( $L_{Aeq, 15 \text{ minutes}}$ ) of between 45dBA and 55dBA depending upon the zoning (residential and rural respectively). This corresponds to an indoor level of between 25dBA and 35dBA. For this specific application, the criteria assume that windows will be closed. This is because the frost fan only comes into operation at temperatures of below freezing (normally about -2°C).

The level given in this Code of Practice originated from guidelines provided by the South Australian EPA and tested in the Land and Environment Court of New South Wales<sup>6</sup>. Arguments for the 'Right to Farm' were contested against the right to peace and quiet in a night time, rural environment. Judge Talbot concluded that:

*Pursuant to s.39 of the Land and Environment Court Act 1979, the Court determines that in accordance with s.264 of the PEO Act, any noise control notices given in writing to the applicant prohibit the company from causing the frost control fan, erected on Farm 1876, Boorga Road, Lake Wyangan, to be operated in such a manner as to cause the emission from the premises between the hours of 22.00 hours and 07.00 hours on any day, of noise that when measured at a point one metre from any residential bedroom window outside the subject property is in excess of 55dBA  $L_{Aeq}$ .*

The background level in the rural area in question, between the hours of 22.00 hours and 07.00 hours was generally below 30dBA. Hence the decision, in these specific circumstances, allows a fixed value, night time noise limit which is more than background plus 25dB.

1.3.3 *NSW EPA Industrial Noise Policy*

The assessment procedure in the NSW EPA *Industrial Noise Policy* (2000) has two components. There are criteria for 'intrusive noise', which is based on the 'background plus' method, and criteria for maintaining noise level amenity, which is based on fixed values. The 'acceptable' amenity criteria ( $L_{Aeq, \text{period}}$ ) for a rural area are 50dBA day; 45dBA evening and 40dBA night. The 'recommended maximums' for a rural area are 55dBA day; 50dBA evening and 45dBA night.

1.3.4 *NSW EPA Prevention Notice*

The NSW EPA can (and does) or an ARA (eg, LCC) provide noise limits, within a Prevention Notice made under s.95 of the POEO Act 1997 for special events or circumstances. This is particularly the case where the duration or the number of events per year are limited. These are often based on fixed values rather than background-plus criteria. For example sporting events may be limited to a  $L_{Amax}$  of 55dBA or 60dBA, whereas concerts may be limited to a  $L_{Amax}$  of 70dBA or 80dBA at the nearest residential boundary positions.

<sup>5</sup> WHO 'Occupational and Community Noise Fact Sheet No. 258', February 2001.

<sup>6</sup> Citation: Sumer Produce Pty Ltd v Griffith City Council [2000]

### 1.3.5 Queensland Acoustic Quality Objective

As part of the Environmental Protection (Noise) Policy (1997) Queensland have established an 'acoustic quality objective'. The purpose of this objective is to encourage an acoustic environment in which the community is not exposed to levels that would cause 10% or more of the urban population to be highly annoyed by noise. The level is set at 55dBA, measured as the long term  $L_{Aeq, 24 \text{ hours}}$ , outside of a noise sensitive place.

### 1.3.6 South Australia Environment Protection (Industrial Noise) Policy

The South Australia EPA information sheet on environmental noise (July 2002) gives maximum noise levels, for industrial and other non-domestic noise in rural or predominantly rural situations of 47dBA between the hours of 7am to 10pm and 40dBA between the hours of 10pm to 7am. This is covered in legislation by the SA Environment Protection (Industrial Noise) Policy 1994.

### 1.3.7 EPA (NSW) Environmental Criteria for Road Traffic Noise

The EPA (NSW) has set environmental criteria for road traffic noise for situations where new roads, redevelopment of roads and new residential land use affected by road traffic noise occurs. Here the criteria are between  $L_{Aeq, 1 \text{ hour}}$  of 50dBA (day) and  $L_{Aeq, 1 \text{ hour}}$  of 45dBA (night) to  $L_{Aeq, 15 \text{ hour}}$  of 60dBA (day)  $L_{Aeq, 9 \text{ hour}}$  of 55dBA (night), depending upon the type of development and the type of area.

### 1.3.8 Lismore City Council's Noise Policy for On-Farm Processing of Macadamia Nuts

In the Lismore area, the Council is the Appropriate Regulatory Authority (ARA) under EPA's NSW Industrial Noise Policy, ("INP") dated January 2000. This is a non-mandatory document developed by EPA for use by them as part of the licensing process for industries.

It is up to a Council as an independent regulator under the legislation as to what noise guidelines they adopt. Hence, if Council sets a noise performance target of

"x"dBA that is "y"dB above background noise levels for de-husking facilities, that is their decision as a 'reasonable person' in balancing the expectations of all interested parties.

Lismore and most Councils currently require a noise performance target of 5dB above the background noise level when measured 1.5 metres from the external wall of the nearest habitable room of the affected residence between specified operating hours.

## 2. Occupational Health and Safety – Hearing Protection

Noise exposure levels above an eight-hour equivalent of 80dBA require the use of hearing protection and ( $L_{Aeq, 8 \text{ hr}}$ ) 85dBA is a legal limit for exposure. Noise levels near to the de-husking operation in macadamia nut processing operations are likely to be the cause of exposures over ( $L_{Aeq, 8 \text{ hr}}$ ) 85dBA. At 90dBA the eight-hour equivalent of 85dBA is reached after 2.5 hours and at 95dBA the eight-hour equivalent of 85dBA is reached after 70 minutes.

The NSW *Occupational Health & Safety Act, 2000* No. 40 places a general duty on employers to ensure the health, safety and welfare at work of all of their employees which includes hearing conservation. In addition to providing training there is a duty to maintain plant and systems of work that are safe and without risk to health.

The NSW *Occupational Health and Safety Regulation 2001* came into effect on 1 September 2001. This Regulation sets an eight-hour energy average ( $L_{Aeq, 8hr}$ ) limit of 85dBA and a peak noise exposure level limit of 140dBC under Chapter 4, Part 4.3, Division 4 – Noise Management. An employer must ensure that appropriate control measures are taken if a person is exposed to noise levels exceeding either of these limits.

The maximum current (2002) penalty for a Company found guilty of not taking the

appropriate control measures is \$27,500 for a first offence. For individuals the maximum penalty is \$2,750 for a first offence. There is an additional penalty for a Company who is a previous offender. This can be up to \$275,000, two years' imprisonment, or both.

The National Occupational Health and Safety Commission (NOHSC) have produced a National Standard for Occupational Noise<sup>7</sup> which gives an exposure limit in the occupational environment for an 8-hour equivalent continuous 'A' frequency weighted sound pressure level ( $L_{Aeq, 8hr}$ ) of 85dBA and a peak level of 140dBC. Any exceedance of the National Standard will place the employee at risk of potential hearing damage.

The Australian Standard AS/NZS 1269, 1998 'Occupational noise management' states:<sup>8</sup>

*if noise-induced hearing impairment is to be kept to not greater than 2dB for 95 percent of the population at any frequency, then exposure levels must be kept to not greater than 80dBA.*

The Australian Standard AS/NZS 1269, 1998 also states:

*shift durations of 10 hours or longer involve a degree of risk greater than that indicated by noise exposure level normalised to an equivalent 8 hour exposure.<sup>9</sup>*

An additional adjustment of +1dB is added to the 8-hour equivalent exposure for shifts of 10 to 14 hours duration.

### 3. Offensive Noise – Workplace Noise (OH&S)

Excessive noise for long periods at work can cause deafness to those in close

proximity and cause disturbance to neighbours.

The first step in controlling noise at work is to carry out an assessment and measure the amount of noise at each work site with the nut processing machinery operating at full capacity.

#### 3.1 How Much Noise is too Much?

There are very few agricultural implements which generate noise levels below 85dBA.

When considering the noise output, the time spent undertaking activities in the noise or exposure to the noise also has to be taken into account. Every increase of 3 decibels doubles the energy of the noise. The time required to exceed regulating exposures is halved for each 3dB noise level increase:

Examples of typical noise levels:

Noise source	Noise level dBA*
Quiet countryside	25-35
Tractor idling	75-80
Tractor working hard (without cab)	96-102
Tractor working hard (with cab)	75-82
Orchard sprayer	85-106
Workshop grinder/ angle grinder	99-105
Chainsaw (idling)	80-90
Chainsaw (cutting)	105-120
Motor mower	85-100
Jet aircraft taking off 10 metres away	120-150

\* The threshold of pain is in the 120-140dBA range.

### 4. Noise Control Techniques

Where it is found (or predicted) that noise levels from the on-farm processing of macadamia nuts exceed the noise criteria, mitigation in the form of noise control should be carried out. A number of factors must be taken into consideration when developing practical and effective noise control measures. Apart from technical considerations, any modifications must

<sup>7</sup> NOHSC: 1007 (2000).

<sup>8</sup> AS/NZS 1269.4:1998, Appendix F, p35.

<sup>9</sup> AS/NZS 1269.4:1998, para 8.4, p16.

also take into account production, maintenance and operator acceptability.

In many cases a range of methods need to be employed to control noise problems. There are various strategies, which should be considered. This is often known as the hierarchy of noise control as shown below:

*Noise Control Options:*

1. *Design – noise is ‘designed out’ at source.*
2. *Remove the noise or substitute quiet methods.*
3. *Enclose or isolate the noise (or the receiver).*
4. *Place a barrier between the noise and the receiver.*

The emphasis is on controlling the noise at its source. Giving preference to the use of engineering controls achieves this. Engineering noise controls are more effective and more economical at the design and manufacturing stage of the process rather than after the equipment as been purchased.

The first two engineering control methods (i.e., design noise out at source or substitute quiet methods) are the only options which actually eliminate, or at least reduce, the noise rather than just preventing the noise from having a detrimental effect on neighbouring residents or operators of noisy equipment.

The logic of a hierarchy of controls is generally well known and accepted but when it comes to noise control it is not often put into practice. Instead barriers, mufflers and enclosures are considered in the first instance. None of these types of strategies actually reduce the noise of the source; they only stop the noise travelling from the source to the receiver. Also barriers, mufflers and enclosures are all subject to disrepair and human failure. The performance of mufflers is very poor if there are holes in the casing. Enclosures are ineffective if panels are left open. Acoustic walls and fences are close to

worthless if there are gaps underneath or panels missing. A 10% hole in an acoustic wall will let 90% of the noise through. (See also Figure 5 below).

The reason noise control at source is not attempted more frequently is that it is often hard to know where to start. Faced with a large and complex noisy machine perhaps this is not surprising.

Before noise control techniques are applied it is essential that the exact source of the noise is identified. This is not always as obvious as it sounds. People often go from noise problem to noise solution as shown below:

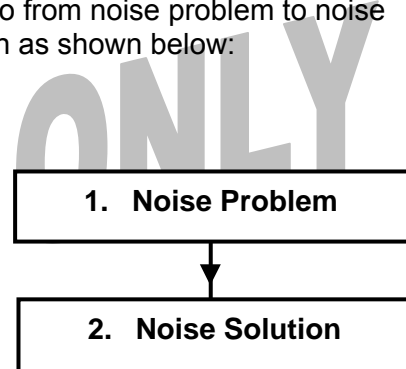

This process misses out the vital stage of noise diagnostics. To do this the exact cause of the noise needs to be identified before noise control solutions are even considered.

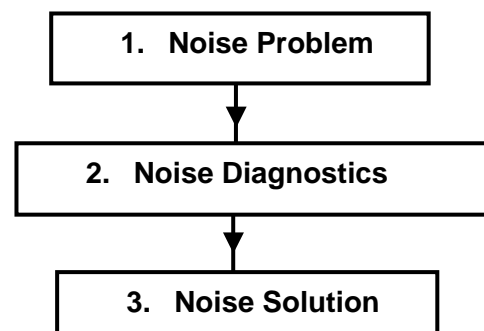

#### 4.1 Noise Source Identification and Diagnostics

It may be assumed that there are hundreds, if not thousands of ways of generating noise. However, nearly all noise sources are either generated in one of two ways i.e., mechanically or aerodynamically (which includes hydro-

dynamically). In fact about 95% of all industrial noise sources can be expressed simply in Table 2 below.

**Table 2 – Noise Sources**

<b>Mechanical Noise</b>	<b>Aerodynamic (Hydrodynamic) Noise</b>
<b>ROTATING MACHINES</b> Gears Bearings Electrical Motors	<b>FANS</b> Impellers In Duct Turbulence
<b>IMPACTS</b> Presses End Stops Mechanical handling	<b>COMPRESSED AIR</b> Blowing Nozzles Air Exhausts Valves
<b>FRICTION</b> Brake, Wheel, Belt Squeal Cutting Tool Squeal Coupling Movement	<b>LIQUID FLOW</b> Water Hammer In Duct Turbulence Valves

Most complex machines, including those used in the macadamia nut processing industry and associated activities will, of course, have a combination of many of the noise sources shown in the table above. The ‘secret’ is to find out where exactly the sources are and how much sound energy each one contains. Noise diagnostics involve the identification of the noise sources and the ranking of them in order to find the noise source with the highest contribution to the overall level. To find out exactly which noise source is dominant is an essential stage of all noise control diagnostics.

#### 4.2 Fundamental Noise Control Techniques

Only once the categorisation, diagnosis and ranking of the noise sources have been carried out, can noise control techniques be considered in detail. There are only a limited number of plant noise control techniques available as listed below:

**Noise Control at Source:** engineering modifications that alter the process of noise generation (limited only by the

experience and imagination of the engineer).

**Vibration Isolation:** introduce a vibration “break” to prevent the transmission of mechanical energy.

**Vibration Damping:** extract and dissipate the energy in vibrating surfaces.

**Silencing:** for aerodynamic sources there are a range of conventional and unconventional attenuators (also called mufflers or “silencers”) available.

**Sound Insulation and Absorption:** prevent the transmission of sound by introducing a barrier (enclosure) lined with acoustic absorbent.

##### 4.2.1 Acoustic Absorbent

Efficient acoustic absorbent materials are porous to allow the sound waves to penetrate and yet dense enough to cause high viscous losses within the small passages as the air excited by the incident sound is “pumped” backwards and forwards through them. A compromise has to be achieved between high porosity (allowing good penetration of sound, but not high viscous losses as the passages are relatively large) and high density (high losses but more sound reflected from the surface).

The effectiveness of an acoustic absorbent lining also depends on the thickness of the absorbent material. Absorbent is at its most efficient when the particle velocity in the air is high (leading to high viscous losses). When a sound wave strikes a reflecting wall, the particle velocity at the surface is zero (molecules adjacent to the wall cannot move), but gradually increases with distance to a maximum that is determined by the wavelength of sound. Thus to be most effective, the absorbent materials should be at least 1/4 wavelength ( $\lambda$ ) thick as shown in Figure 1. Alternatively, an air space can be left behind the absorbent, so that it is placed in the region of highest particle velocity.



Figure 1 – An Application of Acoustic Absorbent

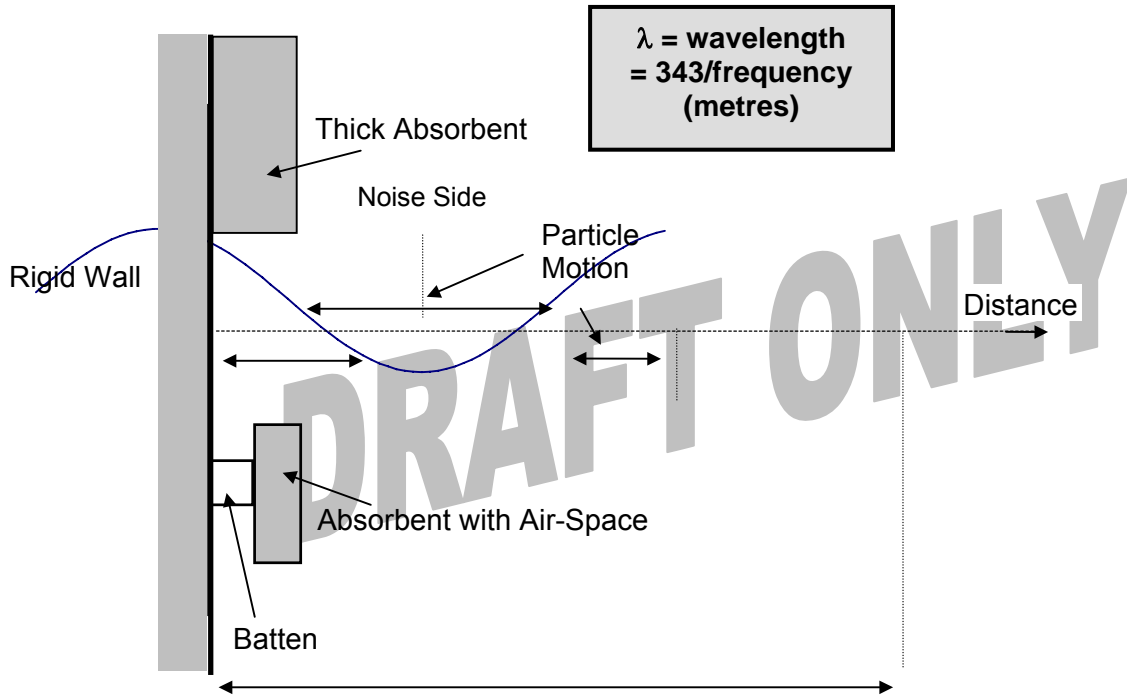

The performance of acoustic absorbent can be measured at different frequencies by placing samples in a reverberant chamber. The change in the rate of decay of the sound (reverberation time) in the chamber due to the presence of the energy dissipating absorbent provides a measure of the efficiency of the absorbent at converting sound energy into heat.

This is called the absorption coefficient whereby a coefficient of 1.0 indicates an efficiency of 100% i.e., no reflected sound.

The graph in Figure 2 shows the performance of a typical industrial acoustic absorbent material with frequency. In some cases the absorption coefficients can be reported as being over 1.0. This is a consequence of the method of measurement and not that the laws of physics having been flouted. One square metre of absorbent has exposed edges that will also absorb sound, i.e. the effective area is in fact greater than 1m<sup>2</sup>.

Figure 2 - Acoustic Absorbent Performance based on 'Pyrotek Sound Sorber' with Metallised Film

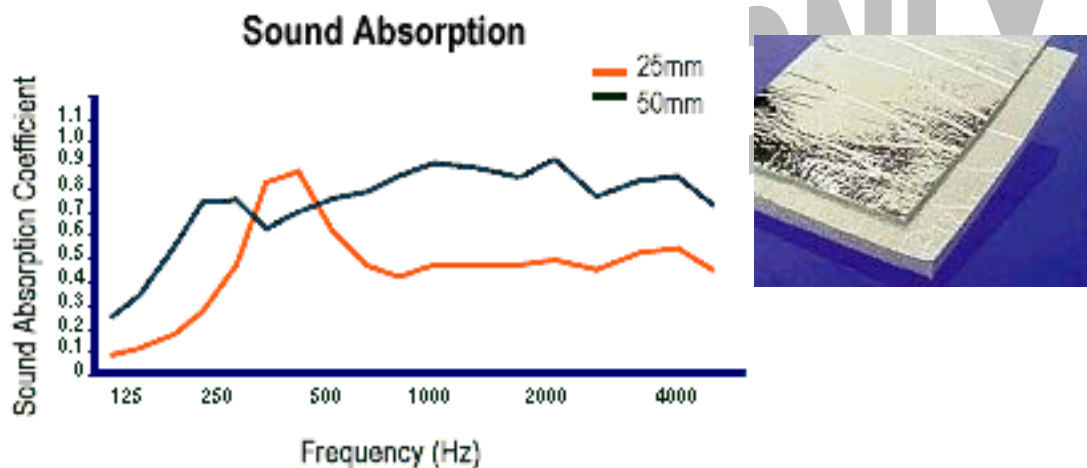

It can be seen that as the frequency of the sound to be absorbed decreases, the thickness of absorbent required increases. It is usually more cost effective to leave an air space behind absorbent panels for low frequency absorption as less material is required.

Note: Acoustic absorbent materials form very poor barriers to the transmission of sound, as they are porous. Confusion sometimes arises because they are very effective thermal insulators (but not sound insulators).

#### 4.2.2 Acoustic Insulation

Acoustically insulating one area from another involves the use of an insulating wall. Ideal insulating materials are limp, massive and impermeable. The Transmission Loss of the construction gives the performance of such insulating walls. Transmission loss is based on the ratio of transmitted sound to incident sound (the transmission coefficient  $\tau$ ).

$$\text{Transmission Loss} = 10 \log (1 / \tau) \text{ dB}$$

Examples of transmission loss characteristics of a number of common constructions are given in Figures 3 and 4.

**Figure 3 – Common Construction Materials: With Good Sound Insulation Performance**

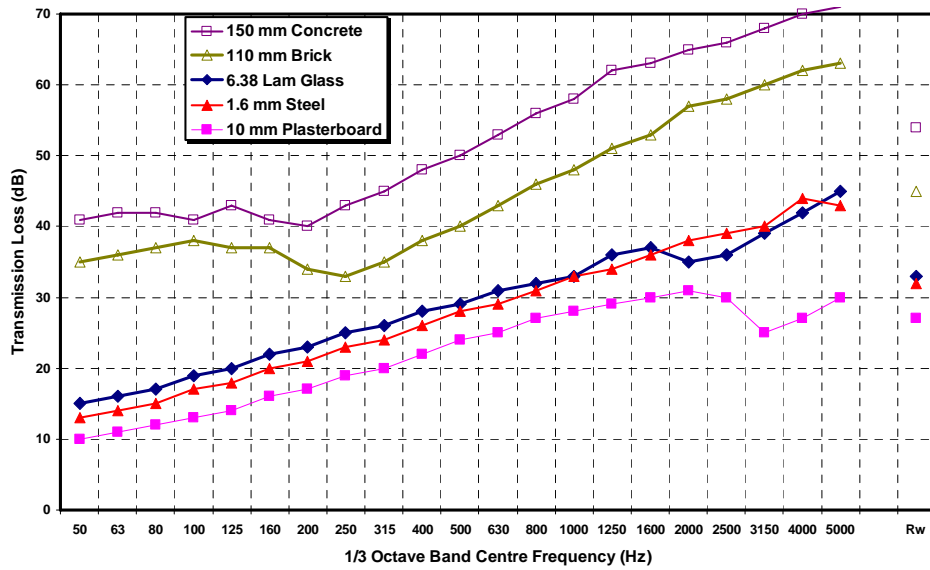

**Figure 4 – Common Construction Materials: With Poor Sound Insulation Performance**

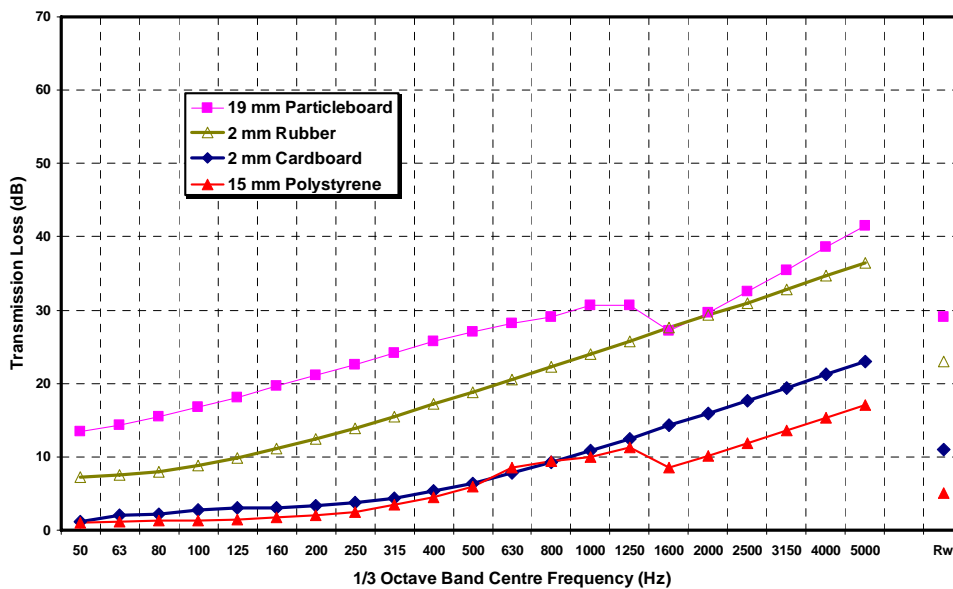

These examples illustrate that the performance of a wall is very dependant on both the mass (density) and the stiffness of the material. This explains the poor sound insulation performance of, for example, the light, 'stiff sandwich' construction door.

Apart from the transmission loss of the materials used, the other important factor that affects the performance of a construction is the presence of holes or leakage paths. This is illustrated in the graph in Figure 5.

Figure 5 – The Effects of Openings in Acoustic Insulation

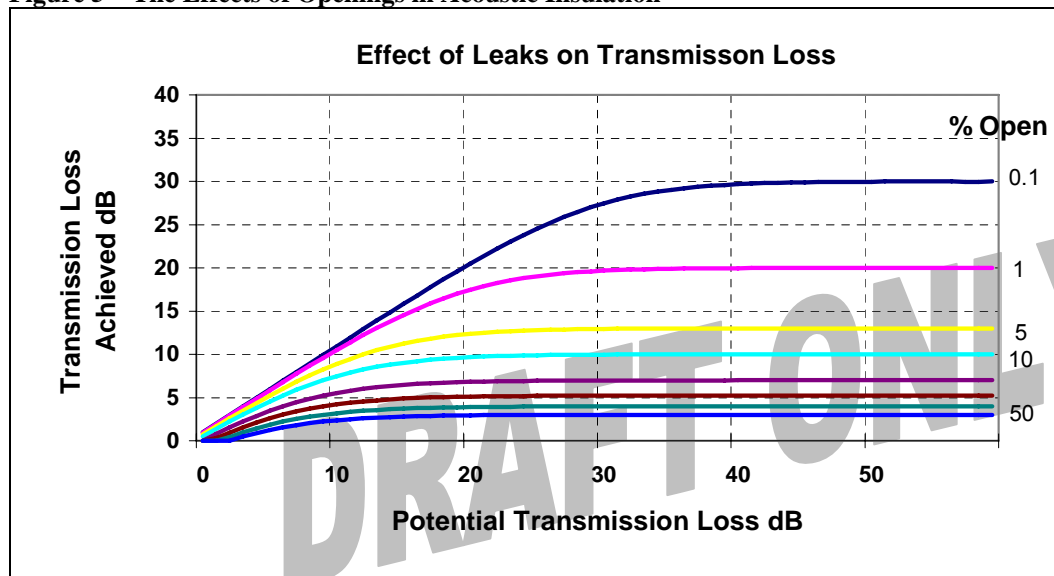

The plots in Figure 5 show that the ultimate attenuation of an acoustically insulating construction is determined by the presence of holes or gaps that afford leakage paths for the sound. A hole with an area that is 1% of the total insulating wall area will limit the performance to a maximum of 20dB transmission loss, no matter what insulating material is used.

Figure 6.

The difference between acoustic **absorbent** and acoustic **insulation** materials is a common cause of confusion as acoustic absorption materials are similar to those used for **thermal** insulation. Acoustic absorbents are by their nature porous and therefore allow the transmission of sound with negligible attenuation. The difference is illustrated in

**Figure 6 – The Principle Uses of Acoustic Absorbent and Insulation**

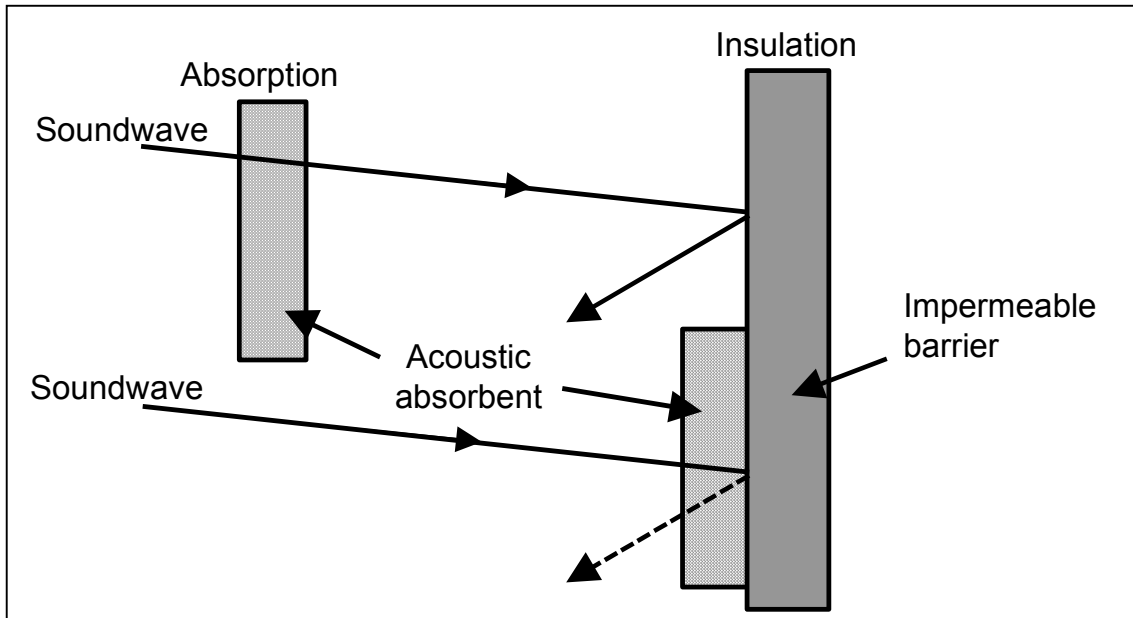

Well designed acoustic enclosures utilise sound insulation materials externally and acoustic absorbent materials internally to prevent reverberant sound built-up. Any air vents must be via acoustic absorbent lined ducts. These should be designed to be as small as possible while still allowing sufficient flow of air to prevent overheating.

reduction of about 5dB; at 0.5 metres this will increase to about 7dB and at 1 metre up to about 10dB. (Note: this is based on the mid-audio range frequencies, ie, 250Hz to 2kHz, and will be less for low frequency noise).

4.2.3 Noise Barriers

Noise barriers are normally constructed from sound insulating materials such as brick, concrete, 'lapped and capped' wooden fences, sheet steel or earth bunds. This reflects the noise away from certain receiver positions. It is essential that there are no holes or gaps under the barrier (see Figure 5 above). A barrier will be effective if the line-of-sight between the noise source and the receiver is obscured. This is illustrated in Figure 7 to Figure 9 below. The distance of 'b' + 'c' – 'a' (and 'd' + 'e' – 'a') is known as the path difference and this should be as high as possible. If the smallest path difference is 0.2 metres the barrier will provide a noise

**Figure 7 - Elevation to Illustrate the Acoustic Barrier Design Principle: The Source and Receiver are at a Distance of 'a' metres apart.**

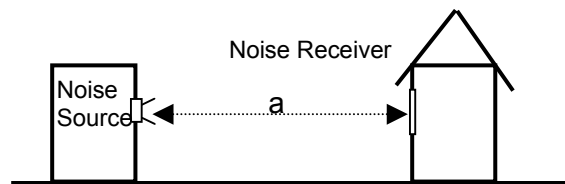

**Figure 8 - Elevation to Illustrate the Acoustic Barrier Design Principle: The Source and Receiver are at a Distance of 'b' + 'c' metres apart.**

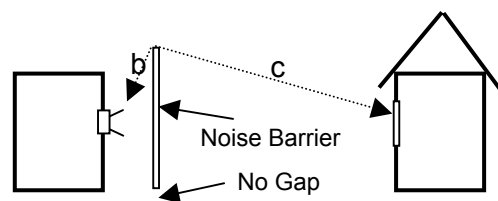

**Figure 9 - Plan View to Illustrate the Acoustic Barrier Design Principle : The Source and Receiver are at a Distance of 'd' + 'e' metres apart**

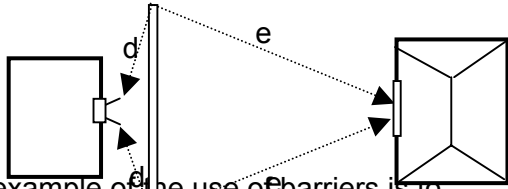

An example of the use of barriers is to instal all equipment inside the de-husking shed including the silo(s). This has the benefit of utilising a noise barrier as well as reducing the moisture content in the air thereby facilitating nut drying.

**4.2.4 Vibration Damping**

Thin machine panels, guards, chutes, hoppers, etc often radiate high levels of noise when subject to impacts. In many cases, the simplest technique for reducing the noise is to 'damp' the panels. The damping mechanism works by extracting vibration energy from the thin sheet and dissipating it as heat. Most damping techniques are only effective on thin sheet metal structures (up to 3mm or 1/8"). The main techniques available are illustrated in Figure 10 and described in outline below:

**Unconstrained Layer Damping:** This technique involves the addition of a layer of high damping material to the surface of the sheet metal. As the substrate bends

during vibration, the damping material is locally stretched and compressed, causing some of the vibration energy to be dissipated within the material.

Unconstrained layer damping is commonly used, for example, on car bodywork in the form of stick-on viscoelastic or bitumastic anti-drumming panels. This technique is only effective on thin flexible panels with very little inherent damping. If the impacts are on the same side as the damping material it will quickly wear out. Damping can still be effective if the damping material is on the other side to the impacts but even better results can be achieved from constrained layer damping.

**Constrained Layer Damping:** This type of damping involves the construction of a layer of high damping material such as rubber-bonded viscoelastic or cork gasket material sandwiched between two sheets of steel of similar material and gauge. This construction causes the constrained layer to shear over its whole area (rather than just locally) during bending, making it much more effective than a simple unconstrained layer. The damping "sandwich" should cover as large an area as convenient (preferably 70% or more) and can be placed on either side of the structure (eg, either on the inside or outside of a chute or hopper).

**Figure 10 - Effective Damping of Vibration in Sheet Metal Structures.**

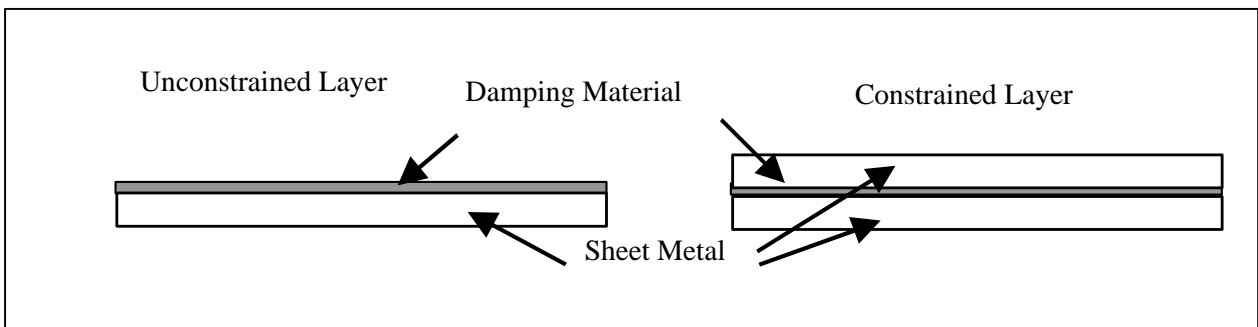

Impact adhesive could be used to stick the construction together, with perhaps an

occasional rivet or screw to ensure that delamination does not occur.

Note: The addition of a damping mechanism to sheet metal should be done so that the stiffness of the structure is kept as low as possible. The addition of stiffening reduces the effectiveness of damping and does not, in itself, dissipate energy.

Where very high damping is required, laminated sheet metal can be bought direct from specialist suppliers (eg, sound deadened steel) for subsequent forming into the component required.

#### 4.2.5 *Vibration Isolation*

Vibration transmitted through a structure can cause problems by affecting the vibration sensitive components of a machine or by causing noise radiation in other areas. Vibration isolation techniques can be used to break the vibration transmission path at some point, attenuating the transmitted vibration (see Figure 11). The general cause for all vibration problems involves a source, a transmission path and a receiver. Isolation can be introduced into the system at either end of the transmission paths, depending on the circumstances.

Vibration isolation involves inserting a flexible element (spring) into the system at some point. The stiffness of the spring is calculated to tune the system such that the natural "bounce" frequency of the isolated component on the spring is well below the operating frequency at which isolation is required.

Isolators are selected so that the natural rocking frequency of the system is below the rotational frequency (or forcing frequency ( $f_f$ )) of the machine (i.e., fan rotational speed in revs/second (rpm/60)). This reduces the vibration that is fed into the supporting structure.

The effectiveness of the isolators is given by the transmissibility of the system. The natural frequency ( $f_n$ ) of the system depends upon the mass ( $m$ ) and the stiffness ( $k$ ) and is found from the formula  $f_n = 0.16 \sqrt{k/m}$ . The natural frequency

should be designed to be at least 30% smaller than the forcing frequency ( $f_f$ ).

Figure 11 - Vibration Isolation Theory

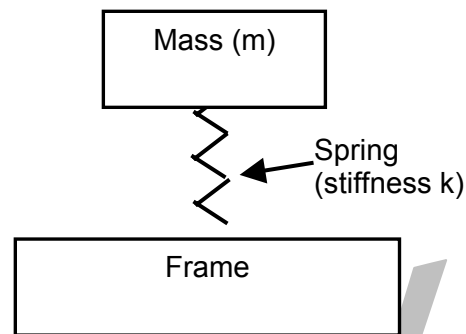

In the case of a variable speed machine mounted on springs, the amount of out-of-balance vibration transmitted into the machine frame on which it is mounted will vary depending on the machine speed compared with the natural frequency of the machine on its mounts. The transmissibility is plotted against speed in Figure 12 below.

**Figure 12 - The Transmissibility Curve: Vibration Amplification (or Attenuation) with the Ratio of Forcing Frequency to Natural Frequency ( $f_f/f_n$ )**

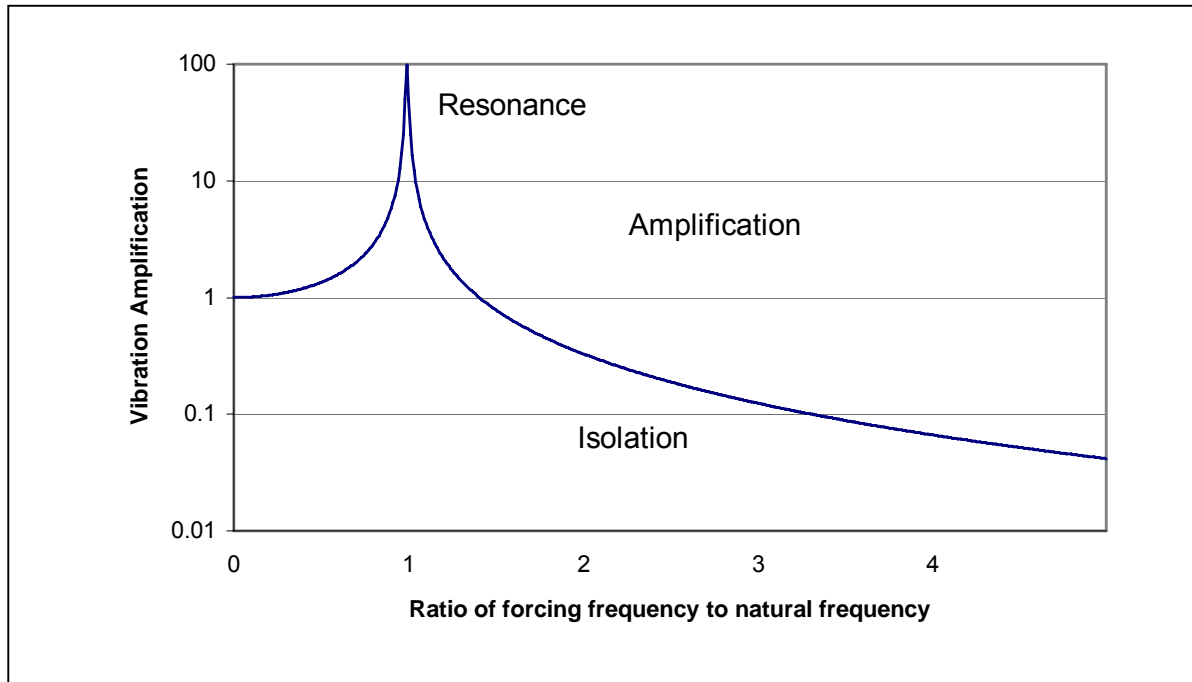

The plot shows that for speeds below  $f_n$ , the vibration is actually amplified by the anti-vibration mounts. Above this speed, the motor becomes increasingly well isolated from the frame. The goal is to obtain a natural frequency of the system ( $f_n$ ) to be about 1/3 of the forcing frequency ( $f_f$ ). In other words the ratio in Figure 11;  $f_f/f_n$  is 3 (or over). The shape of this wave explains why vibration is transmitted into a car body when the idling speed is set too low. As the idling speed drops, the firing frequency gets closer to the natural frequency of the engine mounts and may therefore be amplified.

**Types of Isolator:** There are four main isolator categories with corresponding ranges of natural frequencies for which they are usually used, namely:

Spring Type	$f_n$ (Hz)
Air springs	1.5 – 5
Metal springs	2.5 – 15
Rubbers and elastomers	5 – 35
Composites (cork/rubber pads)	20 upwards

Apart from its operational frequency range, each category has other characteristics which must be borne in mind during the selection procedure. These are:

- load bearing capacity;
- degree of damping required (eg, to control vibration during run-up through resonance); and
- resistance to environmental conditions (temperature, oil etc).

#### 4.2.6 Fan Noise Control

Fans are aerodynamic noise sources that generate pressure fluctuations (sound waves) directly. The resulting noise is often a combination of broadband noise (similar sound energy over a wide range of frequencies) and tonal noise (at the blade passing frequency and multiples). The acceptability of the noise from a particular fan installation depends on whether the problem is noise nuisance (when tonal noise is particularly important) or possible hearing damage (when the frequency content and absolute amplitude are important).



**Installation:** A number of factors will affect the noise from a fan installation. Before choosing noise control measures, diagnostic tests should be made to determine the relative contributions of the aerodynamic and mechanically transmitted noise components.

In some cases fan noise is greatly increased due to the fan being rigidly connected to a large radiating body such as a silo, metal shed or enclosure. Here a significant noise reduction can be achieved by fitting resilient (rubber) mounts and hence vibration isolating the fan from the enclosure (see Section 4.2.5 above).

**Attenuators (Silencers):** Commercially available attenuators (also called mufflers or silencers) can be used to reduce the aerodynamic fan noise transmitted down a duct.

The usual design types are either reactive or absorptive consisting of a number of acoustic absorbent lined slots (splitter silencer) that can give, in relatively short lengths, a high performance. About 10dB to 20dB is achievable at low frequency (63Hz to 125Hz) and 20dB to 45dB at mid frequency (500Hz to 1kHz).

Circular attenuators are also readily available with inside diameters and lengths of about 300mm to 2000mm. Open circular attenuators can provide a noise reduction of 2dB to 9dB at low frequency (63Hz to 125Hz) and 10dB to 20dB at mid frequency (500Hz to 1kHz). Padded circular attenuators can provide a noise reduction of 4dB to 15dB at low frequency (63Hz to 125Hz) and 10dB to 30dB at mid frequency (500Hz to 1kHz) but may cause a higher pressure drop across the system.

Manufacturers will supply performance data in terms of maximum flow rate, pressure drop and noise reduction with frequency. In some cases, sufficient attenuation can be gained by lining lengths (and in particular bends) of the existing ductwork with acoustic absorbent.

Lining an attenuator will generally produce a lower transmission loss at the peak frequency but an improved transmission loss over a broader frequency band.

The correct and incorrect ways for fan installation are shown diagrammatically in Figure 13.

**Figure 13 - The Rights and Wrongs of Fan Installation.**

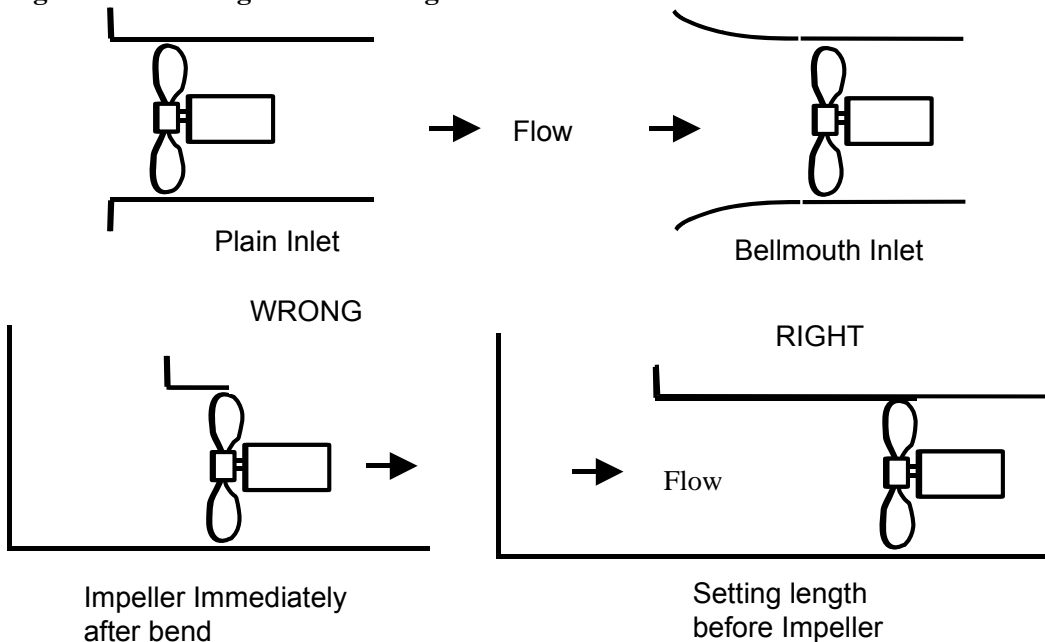

**APPENDIX B: SUMMARY OF RESPONSIBILITIES FOR NOISE MANAGEMENT OF ON-FARM  
PROCESSING OF MACADAMIA NUTS**

Responsibility	Grower	Machinery/ Equipment Manufacturer	Council	Residents/ Neighbours
<b>1. Establishing a New De-Husking Plant</b>	✓	✓	✓	✓
1.1 Prepare a plan	✓	✓	✓	✗
1.2 Noise impact assessment	✓	✓	✓	✗
1.3 Regulatory and compliance aspects	✓	✗	✗	✗
1.4 Designing a de-husking facility	✓	✓	✗	✗
1.4.1 Environmental Aspects	✓	✓	✓	✓
1.4.2 Buffer zone	✓	✗	✓	✓
1.4.3 Detailed design	✓	✓	✗	✗
1.5 Equipment installation and commissioning	✓	✓	✗	✗
1.6 Equipment operation and maintenance	✓	✓	✗	✗
1.6.1 Operator's skills	✓	✓	✗	✗
1.6.2 Human resource issues	✓	✗	✗	✗
1.6.3 Operation and maintenance documentation	✓	✓	✗	✗
1.7 Maintaining community relations	✓	✓	✓	✓
1.8 Planning and community relations	✓	✗	✓	✓
1.8.1 Intending purchasers – Council responsibility	✓	✗	✓	✗
1.8.2 Tenants in rural areas	✓	✗	✓	✓
1.9 Hours of operation	✓	✗	✗	✗
<b>2. Operating Existing De-Husking Facility – Noise Mgmt</b>	✓	✓	✓	✓
2.1 Allegation of offensive noise	✓	✗	✓	✓
2.2 Noise problem	✓	✓	✓	✓
2.2.1 Identifying sources of noise	✓	✓	✓	✗
2.3 Noise assessment	✓	✓	✗	✗
2.4 Controlling noise	✓	✓	✗	✗
2.4.1 Controlling noise – purchase “quieter” equipment	✓	✓	✗	✗
2.4.2 Controlling noise – engineering noise control	✓	✓	✗	✗
2.4.3 Controlling noise – administrative control	✓	✗	✗	✗
2.4.4 Controlling noise – personal hearing protectors	✓	✗	✗	✗
2.5 Noise measurements	✓	✗	✓	✗
2.5.1 Measurement procedure	✓	✗	✓	✗
2.6 Elimination or reduction of noise	✓	✓	✗	✗
2.7 Prevention of noise	✓	✓	✗	✗
<b>3. Rectifying Noise Problems when Silo Fans are Source</b>	✓	✓	✗	✗
3.1 Fan noise control	✓	✓	✗	✗
3.1.1 Elimination or reduction of fan noise	✓	✓	✗	✗

**APPENDIX C: GLOSSARY OF FREQUENTLY USED TERMS WITH LAY AND SCIENTIFIC DEFINITIONS  
(Relating to Noise in the Environment)**

Term	Lay Definition	Scientific Definition
'A' Weighting	A frequency adjustment to the measured sound, which is very roughly in line with loudness at low sound levels.	A frequency weighting based on the 40-phon equal loudness contour of Fletcher and Munson (1933). The 'A' frequency weighting reduces the physical sound by approx. 26 dB at 63 Hz and 16 dB at 125 Hz.
Absorption Material	Material within which sound energy is converted into heat energy.	A closed cell porous material within which sound energy is converted into heat energy.
Ambient Sound	The energy average ( $L_{Aeq, T}$ ) of sound at a set place and time (T).	Totally encompassing sound in a given situation at a given time composed of all sources near and far, measured by time average of the sound energy.
Background Noise Level	The underlying level of noise from sources other than the noise under investigation. (See $L_{A90, 15 \text{ minute}}$ )	The 'A' frequency weighted, 'Fast' time weighted, sound pressure level that is equalled or exceeded for 90% of the time interval considered in the absence of the noise under investigation.
Barrier	See Noise Barrier.	
Broadband Noise	A noise with a wide range of tones.	A noise with frequency components which are distributed over a broad frequency band.
'C' Weighting	A frequency adjustment to the measured sound, which is very roughly in line with loudness at high sound levels.	A frequency weighting based on the 100-phon equal loudness contour of Fletcher and Munson (1933). The 'C' frequency weighting reduces the physical sound by not more than 3 dB between 31 Hz and 8 kHz.
Damping	A reduction in sound energy by conversion into heat energy.	The reduction in amplitude of a mechanical system with each successive cycle resulting in the dissipation of energy with time (joules per second).
dBA	Abbreviation for 'A' frequency weighted sound pressure level measured in decibels.	Not Applicable.
Decibel (dB)	A unitless scale used to measure sound (usually A frequency weighted) where 20 dBA is a low level and 80 dBA is a high level.	10 times the logarithmic ratio of any two quantities relating to the flow of energy (power). $dB = 10 \log_{10} (w/w_0)$
Frequency (Hz)	The tone or pitch of a sound.	The number of cycles per second of sound pressure fluctuations.
Impulsive Noise	Noise with a high rise in level within a short duration or short durations.	
Intermittent Noise	Noise which changes significantly in level with time.	Noise where the level changes by more than 5 dB over a given time interval.
$L_{Aeq, T}$	The time weighted average of the sound energy over a set measurement time (T).	The value of the 'A' frequency weighted sound pressure level of a continuous steady sound that, within a measurement time interval (T) has the same mean square sound pressure level as a sound under consideration whose level varies with time.
$L_{A1, 1 \text{ minute}}$	The sound level that is exceeded for 0.6-seconds in a 1-minute measurement period.	The 'A' frequency weighted, 'Fast' Time weighted sound pressure level that is equalled or exceeded for 1% of the time interval considered (eg. 1 minute).
$L_{A10, 15 \text{ minute}}$	The sound level that is exceeded for 1.5-minutes in a 15-minute measurement period.	The 'A' frequency weighted, 'Fast' Time weighted sound pressure level that is equalled or exceeded for 10% of the time interval considered (eg. 15 minutes).
$L_{A50, 15 \text{ minute}}$	The sound level that is exceeded for 7.5-minutes in a 15-minute measurement period.	The 'A' frequency weighted, 'Fast' Time weighted sound pressure level that is equalled or exceeded for 50% of the time interval considered (eg. 15 minutes).
$L_{A90, 15 \text{ minute}}$	The sound level that is exceeded for 13.5-minutes in a 15-minute measurement period.	The 'A' frequency weighted, 'Fast' Time weighted sound pressure level that is equalled or exceeded for 90% of the time interval considered (eg. 15 minutes).

Term	Lay Definition	Scientific Definition
$L_{Amax, T}$	The maximum sound level measured over a pre set time interval 'T'.	The 'A' frequency weighted, 'Fast' Time weighted maximum sound pressure level measured in the time interval considered (eg. 1 second).
Level	Amplitude.	Ten times the common logarithm of the ratio of two quantities of the same kind.
Loudness	The perceived volume of sound.	The attribute of auditory sensation in terms of which sounds may be ordered on a scale extending from soft to loud.
Low Frequency Noise	Noise with a high level of bass.	Noise which is prominently at or below 125 Hz.
Noise	Unwanted, harmful or inharmonious sound.	Sound pressure level of a source in question excluding ambient sound pressure levels.
Noise Annoyance	A noise which causes annoyance due to the level, tonal or temporal characteristics.	The psychological feeling of discomfort due to the perception of unwanted sound.
Noise Barrier	Normally constructed from sound insulating materials such as brick, concrete, lapped and capped wooden fence, sheet steel or earth bunds to reflect the noise away from certain receiver positions. It is essential that there are no holes or gaps in or under the barrier.	
Pressure	The compaction of air molecules.	The force per unit area acting on a surface. The unit for pressure in the pascal (Pa). 1 bar = 10,000 Pa.
Sound Power Level ( $L_w$ )	The inherent sound of a machine when measured in Decibels.	The level of the root-mean-square (rms) sound power in decibels given by $L_p = 10 \log_{10} (w/w_0)^2$ .
Sound Pressure Level ( $L_p$ )	The sound pressure when measured in Decibels.	The level of the root-mean-square (rms) sound pressure in decibels given by $L_p = 10 \log_{10} (p/p_0)^2$ .
Sound Pressure (p)	The variation in pressure due to an acoustic disturbance.	The root-mean-square (rms) sound pressure in pascals (Pa).
Tonal Noise	A noise with a discrete pitch or discrete range of tones.	A noise where one or more particular frequencies can be clearly identified as significantly greater in level than the adjacent frequencies.

**APPENDIX D: CASE STUDIES ON NOISE PROBLEMS****PROXIMITY OF RURAL RESIDENTIAL NEIGHBOUR AND USE OF OLD EQUIPMENT**

A grower developing a de-husking facility for a small orchard obtained very old second-hand equipment and installed it in an existing steel machinery shed located on the boundary of the property. The processing equipment, including a silo with a fan was placed at the boundary end of the shed facing the residential neighbour. The neighbour complained about the noise, particularly from the impact of nuts entering the silo. A number of noise reduction measures were implemented by the grower. These included:

- erection of a number of poles 3 to 4 metres high along the boundary with carpet hung on wires between them;
- placing socks on pipes to reduce the speed and length of travel of nuts into the silo;
- double glazing the window and door facing the boundary;
- enclosing the machinery area inside the shed with blocks; and
- fitting a silencer to the external pipe which removes the shredded husks.

This case study highlights a number of issues and problems as follows:

- locating the shed on the boundary beside the residential neighbour provided no noise reduction through distance or vegetation buffering;
- old equipment produces more noise as it is not fitted with sound reduction features, is made of thin steel plate which vibrates and has worn cogs, belts, chains and pulleys which contribute additional noise;
- carpet does not create a sound barrier and therefore was unsuitable to reduce noise and in addition created an eyesore for the neighbour;
- the enclosure of the equipment with blocks would make it extremely noisy for the operator and would be likely to contravene OH&S standards and requirements;
- use of the facility is difficult due to the extremely close proximity to the boundary; a tractor with a load of nuts to be processed requires considerable manoeuvring to unload into the hopper; and
- the external ventilation sources of a window and a door have to be kept closed to restrict noise.

The most important lessons from this case study are that not enough consideration was given to location before developing the facility. Also, after problems were identified a piecemeal approach to noise attenuation was adopted rather than an holistic approach which identifies the problem, diagnoses the cause and plans for the complete resolution of the problem(s).

**MULTIPLE RURAL RESIDENCES ON A RURAL ROAD**

A Development Application was made to Council to expand an existing farm shed to house a macadamia de-husking plant. The shed was located across a rural road from 3 rural residences. Approval was given with a set maximum dBA noise level. Subsequently the orchard went into full production with a large volume of nuts being processed.

The neighbour directly across the road complained of excessive noise and Council investigated. The complaint was confirmed with noise levels as high as 85dBA, however it took over two years for the grower to achieve the required noise level.

While the grower utilised the services of an engineering consultant to rectify the problem, the process was done in a sequential manner with each change requiring testing and retesting. A holistic approach was not taken and this as well as a number of management issues contributed to the length of time required to resolve the problem.

This case study highlights a number of key issues and requirements:

- Councils must respond to resident complaints and use their powers to ensure that the problem is rectified as a matter of urgency; it is unacceptable for a resident to have to endure excessive noise for over two years;
- the use of fully qualified, accredited and experienced acoustical consultants should assist in providing an overall solution;
- an economic analysis of all the options available for siting a de-husking shed may have shown that an alternative, less sensitive location may be far more cost effective over a five year period when factors such as noise attenuation, power, transport and resources are taken into consideration;
- implementation of a complete solution down to the smallest component can be required to achieve the noise output level required when neighbours are nearby;
- some components such as a hammer mill are so noisy that they will never meet a reasonable noise level;
- machinery manufacturers designing their equipment for noise attenuation can minimise noise problems from the outset;
- the noise output from a silo with a top mounted high speed fan can vary significantly when compared with a bottom mounted low speed fan; and
- paying attention to OH&S rules and regulations for noise impacts will often significantly assist both staff and neighbours.

## Attachment 1: The POEO Act Provisions

The POEO Act which came into force in 1999, is the responsibility of the EPA. Under the powers delegated by the EPA to the Appropriate Regulatory Authority (Lismore City Council et al), there are a range of enforcement actions when an unacceptable level of noise has been emitted. Details of these have been included in Attachment 1. These are:

- **Noise Control Notice.** Used by authorised officers when setting a noise level is the most effective way to resolve the problem, there is single or small number of items making the noise and noise level reductions are realistic and can be carried out. Specifies the noise level that must be met and a time frame. This notice may also specify a particular time during which the restriction applies or does not apply. The sound levels that are specified in the notice may be determined by reference to Council's or EPA's noise control guidelines as defined in the INP.
- **Prevention Notice.** This may be issued by an authorised officer to control an activity that is being conducted in an 'environmentally unsatisfactory manner' and management practices need to improve to resolve the problem. Usually used for more complex issues when more than one item is the source of the noise and it is not reasonable to set a noise level to be met. Specifies the action to be taken (eg, an action plan, monitoring, measurement, mitigation and submission of reports) to resolve the problem and a time frame. Compliance cost notices may be issued to recover costs associated with issuing a prevention notice.
- **Noise Abatement Direction.** An authorised officer may issue a direction to require the emission of offensive noise to stop immediately. Specifies the type of offense. Essentially a warning with a fine if not obeyed. These directions are designed for 'one-off' problems (eg, a pneumatic drill and noisy parties). Such a direction may be issued verbally or in writing.
- **Noise Abatement Order.** Citizens may apply for an order from a local court to direct a person to cease emissions of an offensive noise.

The penalties which can be imposed under the Act can be severe, depending on the type of offence and the enforcement notice issued. Fines are twice as high for corporations than for individuals (eg, in the case of a Noise Control Notice, the fines are: corporations - \$400; and individuals - \$200); while penalties for a successful prosecution are particularly severe (eg, in the case of a Penalty Notice, the penalties are: corporations - \$250,000 and \$120,000 for each day the offence continues; and individuals - \$120,000 and \$60,000 for each day the offence continues).

### Local Council Responsibility

Under the Act a local has the responsibility for managing and regulating neighbourhood noise as well as noise aspects for most industrial and commercial developments.

The Act provides the general approach for everyone to minimise noise. It defines offensive noise and provides mechanisms such as notices and directions to manage noise problems. It is up to the local Council as to what guidelines they adopt in relation to noise performance targets for macadamia nut de-husking facilities and associated activities. In doing this they act as a 'reasonable person' in balancing the expectations of all interested parties. For example, up till now, Lismore City Council has adopted the guidelines within NSW Industrial Noise Policy (INP) as the benchmark for assessing noise impacts.

Where a noise assessment determines that offensive noise emissions are occurring and a land use conflict is established, the response by Lismore City Council has been to issue either a prevention control or noise control notice under the provisions of the POEO Act. Previously a noise performance target (background noise level plus 5dB) has been nominated to be satisfied through implementation of an appropriate works program. Depending on the severity of noise impact, the notice may also control the hours of operation of the de-husking or drying facility as an interim or long-term measure.